

# The Harman Kardon Model hk495i

Manual 97A

## DIGITAL SYNTHESIZED QUARTZ-LOCKED STEREO RECEIVER

# Technical Manual

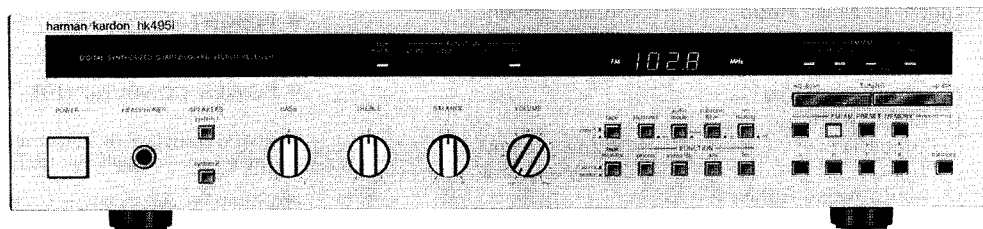

**harman/kardon**

240 Crossways Park West, Woodbury, N.Y. 11797  
1112-H15297A1 P-088509 1850 Printed in Japan

## SPECIFICATIONS

## ● FM SECTION

	Nominal	Limit
Tuning Range	87.5 ~ 108.0 MHz	
50dB Quieting Sensitivity		
Mono	15.7dBf	≤ 19dBf
Stereo	37dBf	≤ 41dBf
Usable Sensitivity	10.7dBf	≤ 15dBf
Image Ratio	42dB	≥ 36dB
IF Rejection	94dB	≥ 75dB
Spurious Response Rejection	74dB	≥ 60dB
Capture Ratio	1.25dB	≤ 2dB
Alternate Channel Selectivity	63dB	≥ 50dB
AM Rejection	57dB	≥ 45dB
Signal to Noise Ratio		
Mono	82dB	≥ 75dB
Stereo	75dB	≥ 70dB
Total Harmonic Distortion		
Mono	0.07%	≤ 0.3%
Stereo	0.06%	≤ 0.4%
Stereo Separation at 1kHz	53dB	≥ 40dB

## ● AM SECTION

Tuning Range	520 ~ 1,710kHz	
Usable Sensitivity		
External Antenna	11μV	≤ 20μV
Loop Antenna	240μV/m	
Selectivity	39dB	≥ 33dB
Signal to Noise Ratio	54dB	≥ 48dB
Image Rejection	40dB	≥ 35dB
IF Rejection	62dB	≥ 50dB

## ● AUDIO SECTION

Usable Sensitivity		
Video/CD	135mV	± 25mV
Phono	2.2mV	± 0.3mV
Signal to Noise Ratio		
Video/CD	82dB	≥ 78dB
Phono	80dB	≥ 72dB

	Nominal	Limit
Channel Separation at 10kHz		
Video/CD	52dB	≥ 43dB
Phono	57dB	≥ 45dB
IM Distortion Ratio	0.1%	≤ 0.2%
RMS Output Power	50W	≥ 45W
8Ω, 1kHz, THD 0.09%		
Damping Factor at 1kHz	70	≥ 60
Tone Control Characteristics		
Bass at 50Hz		
Boost	10dB	± 2dB
Cut	-10dB	± 2dB
Treble at 10kHz		
Boost	10dB	± 2dB
Cut	-10dB	± 2dB
Loudness Control		
at 10kHz	3dB	± 1dB
at 50Hz	10dB	± 2dB
DC Output Voltage		
L channel	0mV	± 60mV
R channel	0mV	± 60mV
RIAA Equalization at		
Tape Out (20Hz/20kHz)	1.2dB	+1.8 dB / -0.5 dB / 0.3dB / -1.0 dB
● DIMENSIONS (W x H x D)	17-1/2" x 4-1/16" x 14-1/2"	(443 x 103 x 368 mm)
● WEIGHT	15lbs 7oz	(7kg)
● POWER SUPPLY	AC120V, 60Hz	
● POWER CONSUMPTION	220W	

This specification is the target of servicing. But, there is a case that the specification is not applicable to the measurement condition and instrument.

Specifications and components subject to change without notice. Overall performance will be maintained or improved.

## LEAKAGE TEST (FOR SERVICE ENGINEERS IN THE U.S.A.)

Before returning the unit to the user, perform the following safety checks:

1. Inspect all lead dress to make certain that leads are not pinched or that hardware is not lodged between the chassis and other metal parts in the unit.
2. Be sure that any protective devices such as nonmetallic control knobs, insulating fishpapers, cabinet backs, adjustment and compartment covers or shields, isolation resistor-capacity networks, mechanical insulators, etc. which were removed for servicing are properly reinstalled.
3. Be sure that no shock hazard exists; check for leakage current using Simpson Model 229 Leakage Tester, standard equipment item No. 21641, RCA Model WT540A or use alternate method as follows: Plug the power cord directly into a 120-volt AC receptacle (do not use an Isolation Transformer for this test). Using two clip leads, connect a 1500 Ohm, 10-watt resistor paralleled by a 0.15 μF capacitor, in series with all exposed metal cabinet parts and a known earth ground, such as a water pipe or conduit. Use a VTVM or VOM with 1000 Ohms per volt, or higher, sensitivity to measure the AC voltage drop across the resistor. (See Diagram.) Move the resistor connection to each exposed metal part having a return path to the chassis (antenna, metal, cabinet, screw heads, knobs and control shafts, escutcheon, etc.) and measure the AC voltage drop across the resistor. (This test should be performed with the power switch in both the On and Off positions.) A reading of 0.35 volt RMS or more is excessive and indicates a potential shock hazard which must be corrected before returning the unit to the owner.

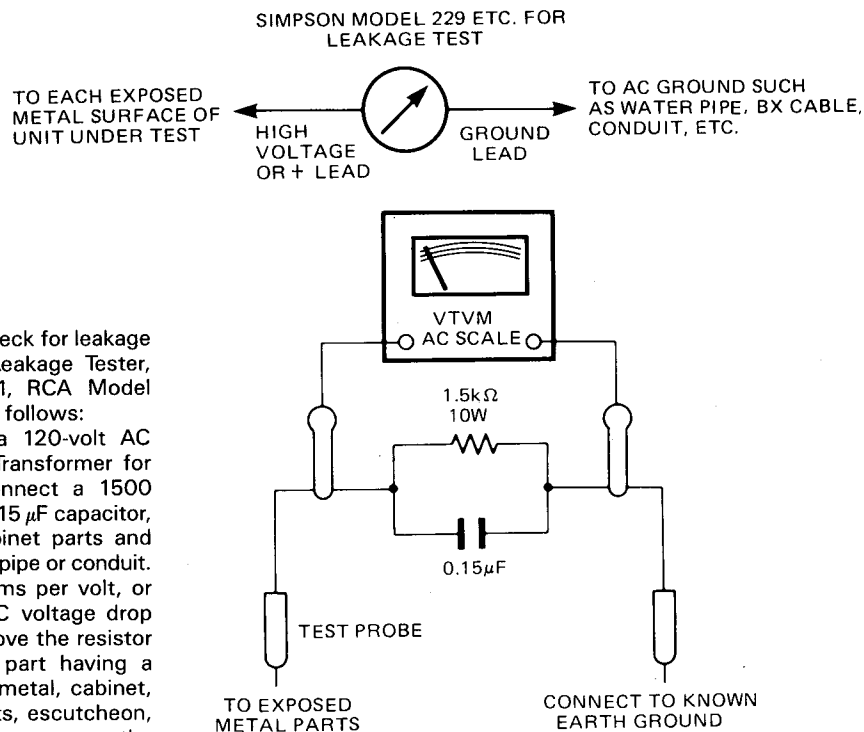

**DISASSEMBLY PROCEDURES (REFER TO PAGES 4 AND 12)**

**1 CABINET TOP (128) REMOVAL**

Remove 6 screws **A** and then remove the Cabinet Top (128).

**2 CABINET BOTTOM (130) REMOVAL**

Remove 8 screws **B** and then remove the Cabinet Bottom (130).

**3 FRONT PANEL ASSEMBLY (101) REMOVAL**

1. Remove the Cabinet Top (128), referring to the previous step 1.
2. Remove 6 screws **C** and then remove the Front Panel Assembly (101).

**4 TUNER P. C. BOARD (PCB-1) REMOVAL**

1. Remove the Cabinet Top (128), referring to the previous step 1.
2. Disconnect LCN5 from CN5 on the Tuner P. C. Board (PCB-1).
3. Open the lid of connectors (CN1, CN2, CN4, CN6 and CN401) on the Tuner P. C. Board (PCB-1) and then disconnect the lead wires.
4. Remove 4 screws **D** and then pull off the Tuner P. C. Board (PCB-1) from the Holder (177).

**5 FREQUENCY DISPLAY P. C. BOARD (PCB-3) REMOVAL**

1. Remove the Front Panel Assembly (101), referring to the previous step 3.
2. Disconnect LCN5 from CN5 on the Tuner P. C. Board (PCB-1).
3. Open the lid of connectors (CN7 and 2) on the Frequency Display P. C. Board (PCB-3) and Tuner P. C. Board (PCB-1) and then disconnect the lead wires.
4. Remove the right and left Holders (183), and then remove the Dial Back Assembly (105) and Dial Panel (134).  
The Holder is fixed with catches at 3 positions.
5. Remove 2 screws **E** and then remove the Frequency Display P. C. Board (PCB-3).

**6 PUSH SWITCHES P. C. BOARD (PCB-4) REMOVAL**

1. Remove the Frequency Display P. C. Board (PCB-3), referring to the previous step 5.
2. Open the lid of connectors (CN401, CN403 and CN407) on the Push Switches P. C. Board (PCB-4) and connectors (CN402 and CN406) on the Power Amp. P. C. Board (PCB-2) and then disconnect the lead wires.
3. Remove 2 screws **F** and then remove the Push Switches P. C. Board (PCB-4).

**7 POWER AMP P. C. BOARD (PCB-2) REMOVAL**

1. Remove the Front Panel Assembly (101), referring to the previous step 3.
2. Remove the Tuner P. C. Board (PCB-1), Frequency Display P. C. Board (PCB-3) and Push Switches P. C. Board (PCB-4), referring to the previous steps 4, 5 and 6.
3. Open the lid of the connector (CN405) on the Power Amp. P. C. Board (PCB-2) and then disconnect the lead wires.
4. Pull out Volume, Balance, Treble and Bass Knobs (103).
5. Remove the Cabinet Bottom (130), referring to the previous step 2.
6. Remove 7 screws **G**.
7. Remove 13 screws **H** and then remove the Cabinet Back Assembly (102).
8. Remove the screw **I** and then remove the Lug Terminal (LUG1).
9. Remove 2 screws **J** and 4 hexagon nuts **K** and then remove the Power Amp. P. C. Board (PCB-2).  
If necessary, unsolder the lead wires connected to the PCB-2.

**GENERAL UNIT PARTS LIST**

Ref. No.	Part No.	Description
101	A443-HK495A	Front Panel Ass'y
102	A424-HK495A	Cabinet Back Ass'y
103	A630-HK495A	Knob Ass'y, Bass, Treble, Balance, Volume
104	A662-HK495A	Push Button Ass'y, Tape Monitor, Phono, Video/CD, AM, FM, Tape, Loudness, Audio Mode, Subsonic Filter, FM Muting, Speakers System 1 and 2
105	A554-HK495A	Dial Back Ass'y
106	B211-HK495A	Chassis Ass'y
128	1414-04601	Cabinet Top
130	1424-16501	Cabinet Bottom
133	1319-0139	Foot
134	1541-04701	Dial Panel
143	1662-21901VN	Push Button, Tuning
145	1660-00401	Push Button, Power
146	1662-22101	Push Button, Preset Memory
157	2218-7001	Bracket
160	2132-7139	Spacer
161	2211-7270	Chassis
162	2211-7272	Chassis
163	2211-7273	Chassis
164	2224-7110	Insulator
165	2216-7162	Shield Plate

Ref. No.	Part No.	Description
166	2219-7879	Bracket
167	2219-8056	Bracket
168	2219-7987	Bracket
169	2219-8057	Bracket
170	2219-8060	Bracket
172	2222-7189	Heat Sink
173	2240-7253	Holder
174	2240-7120	Holder
177	2240-7050	Holder
178	2240-364	Holder
180	2240-7254	Holder
183	2240-7047	Holder
184	2552-301229	Screw (3 x 12mm)
187	2347-300627	Screw (3 x 6mm)
191	2347-300827	Screw (3 x 8mm)
193	2347-300647	Screw (3 x 6mm)
195	2347-400647	Screw (4 x 6mm)
200	2347-301041	Screw (4 x 10mm)
211	2651-210189	Spring
215	2672-7018	Lever
251	2240-7218	Holder, AM Loop Antenna
	1111-J30225	Owner Guide <b>U</b>
	1111-J30226	Owner Guide <b>A</b>
	1221-837144	Packing Box
	1222-7216	Packing Cushion

**U** : U.S.A. model  
**A** : Canada model

\* The part with the above mark is used only in the model made for the particular market the mark indicates.

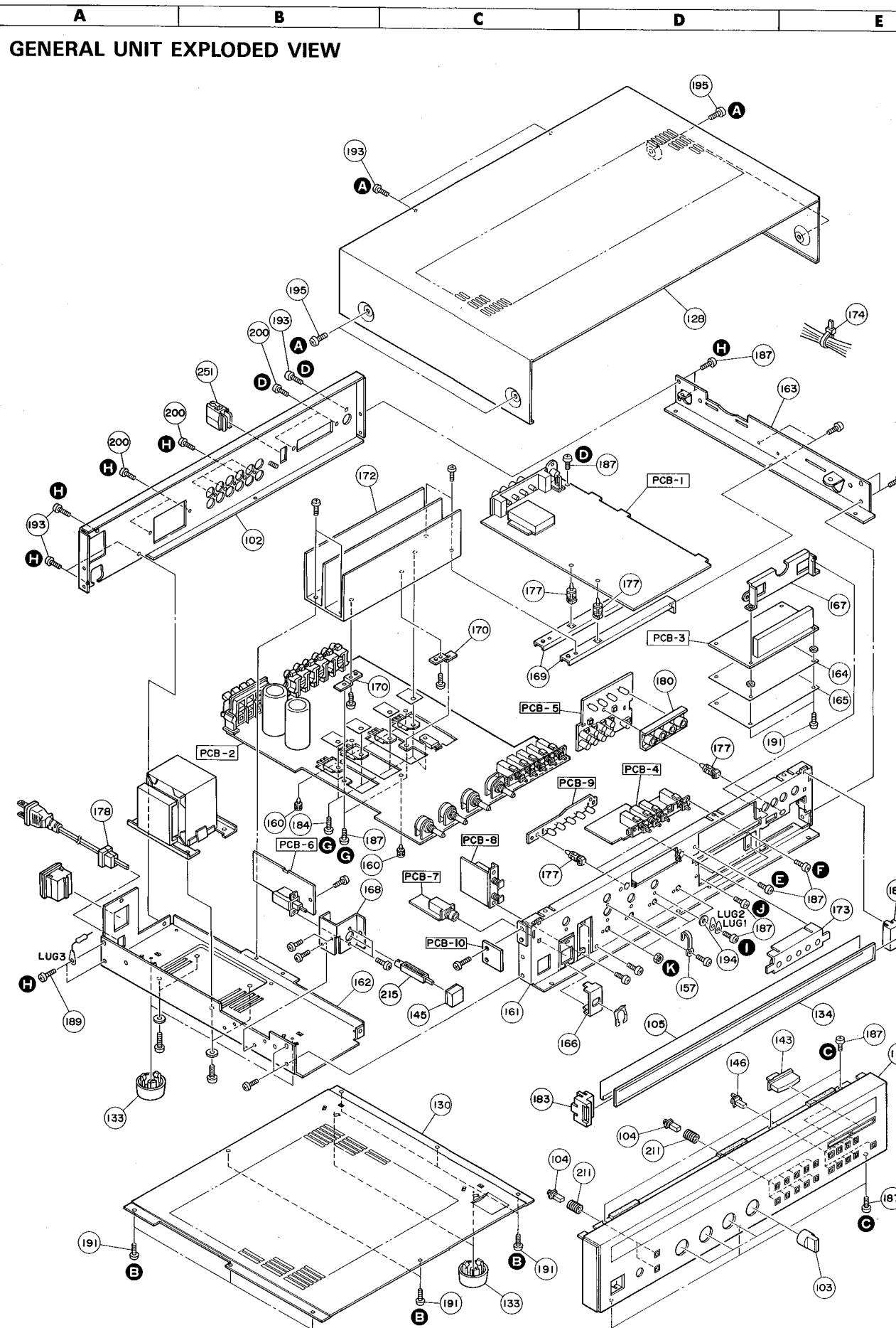

## DISASSEMBLY PROCEDURES (REFER TO PAGES 4 AND 12)

### ① CABINET TOP (128) REMOVAL

Remove 6 screws **A** and then remove the Cabinet Top (128).

### ② CABINET BOTTOM (130) REMOVAL

Remove 8 screws **B** and then remove the Cabinet Bottom (130).

### ③ FRONT PANEL ASSEMBLY (101) REMOVAL

1. Remove the Cabinet Top (128), referring to the previous step ①.
2. Remove 6 screws **C** and then remove the Front Panel Assembly (101).

### ④ TUNER P. C. BOARD (PCB-1) REMOVAL

1. Remove the Cabinet Top (128), referring to the previous step ①.
2. Disconnect LCN5 from CN5 on the Tuner P. C. Board (PCB-1).
3. Open the lid of connectors (CN1, CN2, CN4, CN6 and CN401) on the Tuner P. C. Board (PCB-1) and then disconnect the lead wires.
4. Remove 4 screws **D** and then pull off the Tuner P. C. Board (PCB-1) from the Holder (177).

### ⑤ FREQUENCY DISPLAY P. C. BOARD (PCB-3) REMOVAL

1. Remove the Front Panel Assembly (101), referring to the previous step ③.
2. Disconnect LCN5 from CN5 on the Tuner P. C. Board (PCB-1).
3. Open the lid of connectors (CN7 and 2) on the Frequency Display P. C. Board (PCB-3) and Tuner P. C. Board (PCB-1) and then disconnect the lead wires.
4. Remove the right and left Holders (183), and then remove the Dial Back Assembly (105) and Dial Panel (134).  
The Holder is fixed with catches at 3 positions.
5. Remove 2 screws **E** and then remove the Frequency Display P. C. Board (PCB-3).

### ⑥ PUSH SWITCHES P. C. BOARD (PCB-4) REMOVAL

1. Remove the Frequency Display P. C. Board (PCB-3), referring to the previous step ⑤.
2. Open the lid of connectors (CN401, CN403 and CN407) on the Push Switches P. C. Board (PCB-4) and connectors (CN402 and CN406) on the Power Amp. P. C. Board (PCB-2) and then disconnect the lead wires.
3. Remove 2 screws **F** and then remove the Push Switches P. C. Board (PCB-4).

### ⑦ POWER AMP P. C. BOARD (PCB-2) REMOVAL

1. Remove the Front Panel Assembly (101), referring to the previous step ③.
2. Remove the Tuner P. C. Board (PCB-1), Frequency Display P. C. Board (PCB-3) and Push Switches P. C. Board (PCB-4), referring to the previous steps ④, ⑤ and ⑥.
3. Open the lid of the connector (CN405) on the Power Amp. P. C. Board (PCB-2) and then disconnect the lead wires.
4. Pull out Volume, Balance, Treble and Bass Knobs (103).
5. Remove the Cabinet Bottom (130), referring to the previous step ②.
6. Remove 7 screws **G**.
7. Remove 13 screws **H** and then remove the Cabinet Back Assembly (102).
8. Remove the screw **I** and then remove the Lug Terminal (LUG1).
9. Remove 2 screws **J** and 4 hexagon nuts **K** and then remove the Power Amp. P. C. Board (PCB-2).  
If necessary, unsolder the lead wires connected to the PCB-2.

## GENERAL UNIT PARTS LIST

Ref. No.	Part No.	Description
101	A443-HK495A	Front Panel Ass'y
102	A424-HK495A	Cabinet Back Ass'y
103	A630-HK495A	Knob Ass'y, Bass, Treble, Balance, Volume
104	A662-HK495A	Push Button Ass'y, Tape Monitor, Phono, Video/CD, AM, FM, Tape, Loudness, Audio Mode, Subsonic Filter, FM Muting, Speakers System 1 and 2
105	A554-HK495A	Dial Back Ass'y
106	B211-HK495A	Chassis Ass'y
128	1414-04601	Cabinet Top
130	1424-16501	Cabinet Bottom
133	1319-0139	Foot
134	1541-04701	Dial Panel
143	1662-21901VN	Push Button, Tuning
145	1660-00401	Push Button, Power
146	1662-22101	Push Button, Preset Memory
157	2218-7001	Bracket
160	2132-7139	Spacer
161	2211-7270	Chassis
162	2211-7272	Chassis
163	2211-7273	Chassis
164	2224-7110	Insulator
165	2216-7162	Shield Plate

Ref. No.	Part No.	Description
166	2219-7879	Bracket
167	2219-8056	Bracket
168	2219-7987	Bracket
169	2219-8057	Bracket
170	2219-8060	Bracket
172	2222-7189	Heat Sink
173	2240-7253	Holder
174	2240-7120	Holder
177	2240-7050	Holder
178	2240-364	Holder
180	2240-7254	Holder
183	2240-7047	Holder
184	2552-301229	Screw (3 x 12mm)
187	2347-300627	Screw (3 x 6mm)
191	2347-300827	Screw (3 x 8mm)
193	2347-300647	Screw (3 x 6mm)
195	2347-400647	Screw (4 x 6mm)
200	2347-301041	Screw (4 x 10mm)
211	2651-210189	Spring
215	2672-7018	Lever
251	2240-7218	Holder, AM Loop Antenna
	1111-J30225	Owner Guide <b>U</b>
	1111-J30226	Owner Guide <b>A</b>
	1221-837144	Packing Box
	1222-7216	Packing Cushion

**U** : U.S.A. model

**A** : Canada model

\* The part with the above mark is used only in the model made for the particular market the mark indicates.

A B C D E

# GENERAL UNIT EXPLODED VIEW

1  
2  
3  
4  
5  
6  
7

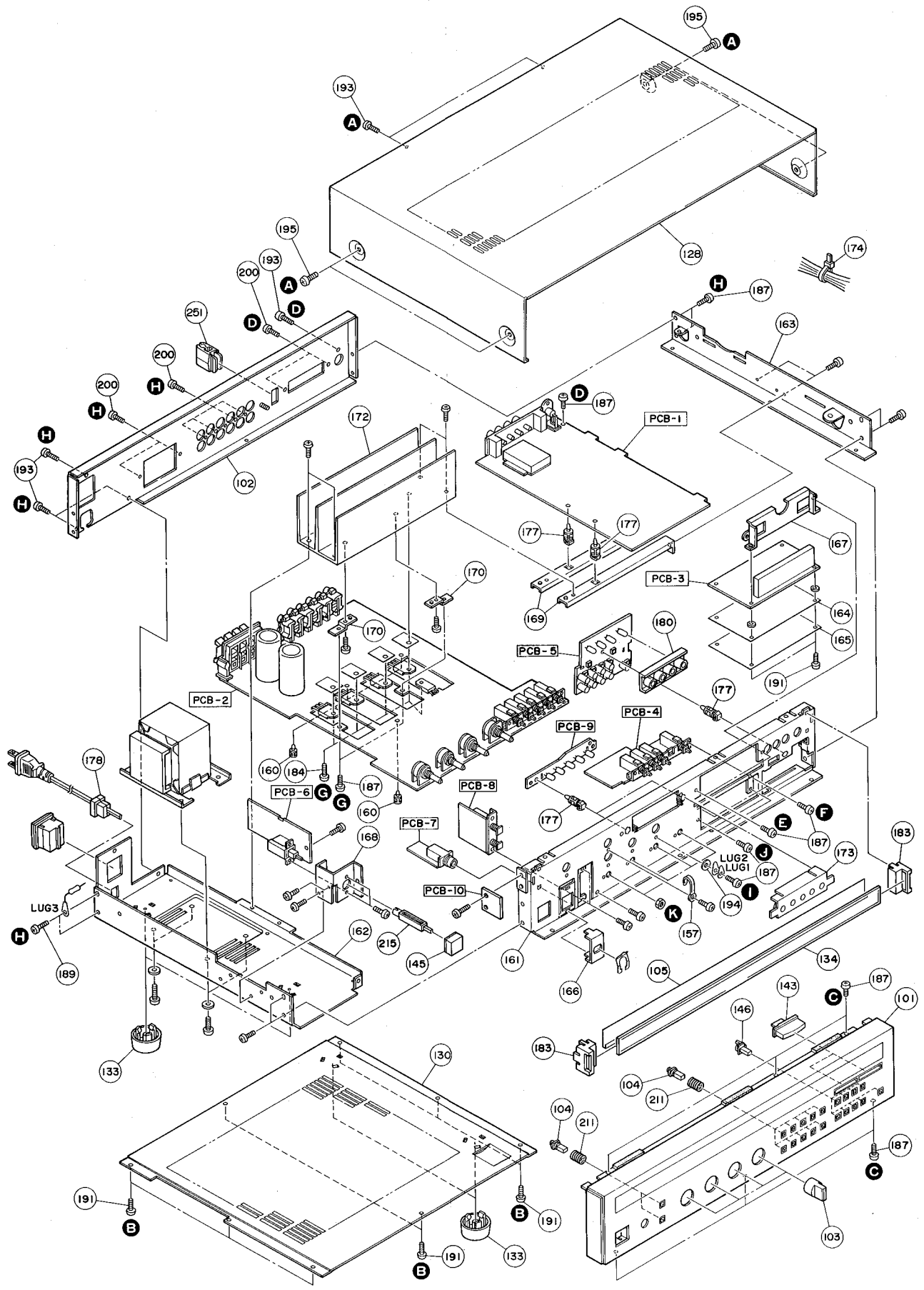

## CIRCUIT DESCRIPTION

### FM TUNER SECTION

The FM signal which has entered through the antenna is high-frequency amplified in Q101 at the front end, mixed with the output of the local oscillators Q103 and Q104 in Q102 and converted into the 10.7MHz intermediate frequency.

The 10.7MHz signal is amplified in the intermediate-frequency amplifying section which consists of Q201, CF201 and CF202 and fed to 1 pin of IC201. In IC201, the signal is transmitted through the IF amplifier in two steps, and after being detected in the quadrature, it is transmitted through the post amplifier to 10 pin and then input to 2 pin of IC301. In IC301, the pilot signal is detected out of the signal which has been fed and 38kHz signal is produced. Then by this signal, stereo signal is demodulated, output from 4 pin for the left channel and from 7 pin for the right channel and transmitted through the low pass filters LPF301 (L ch) and LPF302 (R ch) to the amplifier.

### AM TUNER SECTION

The AM signal which has entered through the antenna is transmitted through the tuning circuit consisting of L251 and TC251 to IC201. In IC201 it undergoes high-frequency amplification, local oscillation, intermediate-frequency amplification and detection, and then output from 12 pin. This signal is turned ON and OFF according to the signal from the input selector at Q252 and fed to 2 pin of IC301.

### AUDIO AMPLIFIER SECTION

The signal which has entered from each input terminal is selected by the input selector, passes through the audio mode switch, balance circuit, volume and loudness circuit and is input into the power amplifier, where it goes through the tone control circuit and after being power amplified, it is transmitted to the speaker terminal. The power amplifier has an over-output protective circuit. If current exceeding the specification flows to Q421, Q423 (L ch), Q422, Q424 (R ch), it is detected at Q5 (L ch) and Q6 (R ch) and the protective circuit consisting of Q1, Q2, Q3 and Q4 draws in the base of Q405 (L ch) and Q406 (R ch), and thus the input signal is cut to protect the circuit.

## TIMING CHART

Frequency display timing chart of IC702 (TC9147AP)

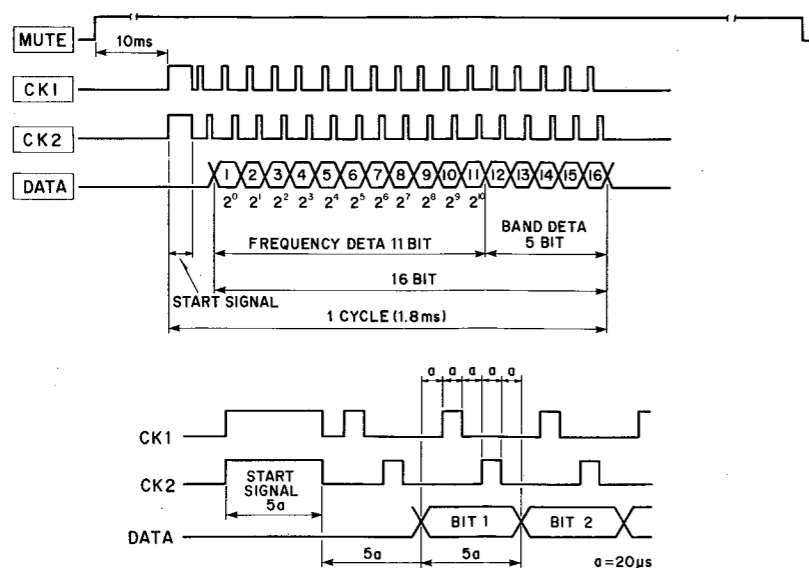

### MUTING CIRCUIT

If FM is received out of tuning or in a very weak field intensity, 8 pin of IC201 becomes high level. This is fed to the base of Q351, whose collector then becomes low level and the collector of Q352 high level. As a result, Q355 (L ch) and Q356 (R ch) are conducted to mute the output.

### SYNTHESIZER SECTION

#### FM

The local oscillation output at the front end is fed to 5 pin of the prescaler IC701 and after being frequency divided into 30 or 32, it is fed to 37 pin of the PLL synthesizer IC702. In IC702, the standard frequency is oscillated by the crystal oscillator, compared with the divided local oscillation output and output to 34 pin. This voltage is level converted at Q701, Q702 and Q703, and fed to the varicap diode at the front end.

#### AM

The local oscillation output is fed from 22 pin of IC201 to 39 pin of IC702. IC702, the standard frequency is oscillated by the crystal oscillator, compared with the local oscillation output and output to 34 pin.

### INDICATOR SECTION

#### Frequency display

The output of 24 to 27 pins of the PLL synthesizer IC702 is fed to the frequency indicating driver IC703. The indicator tube is turned ON by the output decoded in IC703.

#### Signal strength

The voltage corresponding to the signal level is output from 13 pin of IC201 and input into 8 pin of the level comparator IC351. D721, D722 and D723 of the signal strength indicator turn ON according to the signal level.

#### Tuning

8 pin of IC201 becomes low level when tuned and the tuned indicator D724 connected there turns ON.

## BLOCK DIAGRAM

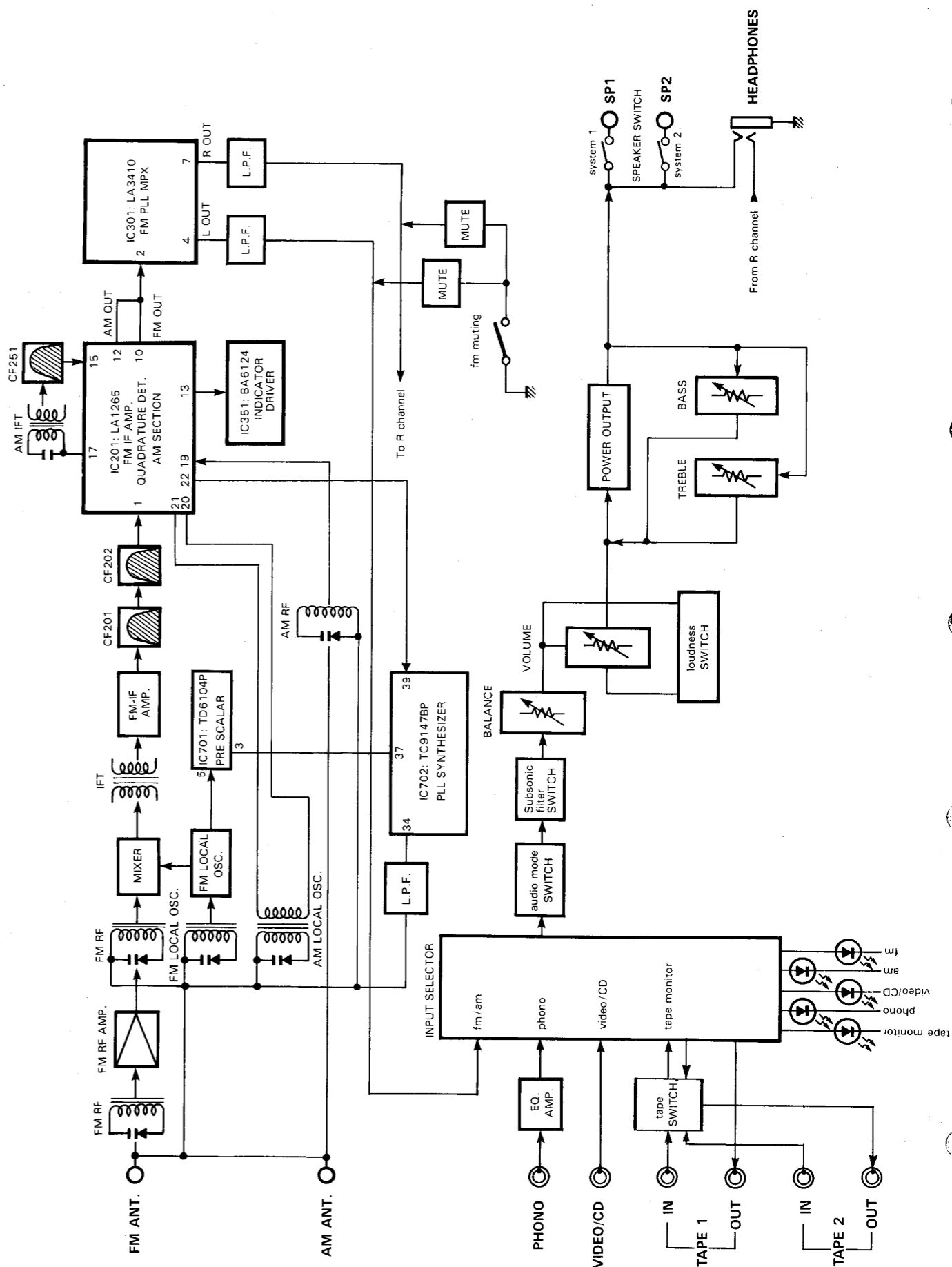

## CIRCUIT DESCRIPTION

### FM TUNER SECTION

The FM signal which has entered through the antenna is high-frequency amplified in Q101 at the front end, mixed with the output of the local oscillators Q103 and Q104 in Q102 and converted into the 10.7MHz intermediate frequency.

The 10.7MHz signal is amplified in the intermediate-frequency amplifying section which consists of Q201, CF201 and CF202 and fed to 1 pin of IC201. In IC201, the signal is transmitted through the IF amplifier in two steps, and after being detected in the quadrature, it is transmitted through the post amplifier to 10 pin and then input to 2 pin of IC301. In IC301, the pilot signal is detected out of the signal which has been fed and 38kHz signal is produced. Then by this signal, stereo signal is demodulated, output from 4 pin for the left channel and from 7 pin for the right channel and transmitted through the low pass filters LPF301 (L ch) and LPF302 (R ch) to the amplifier.

### AM TUNER SECTION

The AM signal which has entered through the antenna is transmitted through the tuning circuit consisting of L251 and TC251 to IC201. In IC201 it undergoes high-frequency amplification, local oscillation, intermediate-frequency amplification and detection, and then output from 12 pin. This signal is turned ON and OFF according to the signal from the input selector at Q252 and fed to 2 pin of IC301.

### AUDIO AMPLIFIER SECTION

The signal which has entered from each input terminal is selected by the input selector, passes through the audio mode switch, balance circuit, volume and loudness circuit and is input into the power amplifier, where it goes through the tone control circuit and after being power amplified, it is transmitted to the speaker terminal. The power amplifier has an over-output protective circuit. If current exceeding the specification flows to Q421, Q423 (L ch), Q422, Q424 (R ch), it is detected at Q5 (L ch) and Q6 (R ch) and the protective circuit consisting of Q1, Q2, Q3 and Q4 draws in the base of Q405 (L ch) and Q406 (R ch), and thus the input signal is cut to protect the circuit.

### MUTING CIRCUIT

If FM is received out of tuning or in a very weak field intensity, 8 pin of IC201 becomes high level. This is fed to the base of Q351, whose collector then becomes low level and the collector of Q352 high level. As a result, Q355 (L ch) and Q356 (R ch) are conducted to mute the output.

### SYNTHESIZER SECTION

#### FM

The local oscillation output at the front end is fed to 5 pin of the prescaler IC701 and after being frequency divided into 30 or 32, it is fed to 37 pin of the PLL synthesizer IC702. In IC702, the standard frequency is oscillated by the crystal oscillator, compared with the divided local oscillation output and output to 34 pin. This voltage is level converted at Q701, Q702 and Q703, and fed to the varicap diode at the front end.

#### AM

The local oscillation output is fed from 22 pin of IC201 to 39 pin of IC702. IC702, the standard frequency is oscillated by the crystal oscillator, compared with the local oscillation output and output to 34 pin.

### INDICATOR SECTION

#### Frequency display

The output of 24 to 27 pins of the PLL synthesizer IC702 is fed to the frequency indicating driver IC703. The indicator tube is turned ON by the output decoded in IC703.

#### Signal strength

The voltage corresponding to the signal level is output from 13 pin of IC201 and input into 8 pin of the level comparator IC351. D721, D722 and D723 of the signal strength indicator turn ON according to the signal level.

#### Tuning

8 pin of IC201 becomes low level when tuned and the tuned indicator D724 connected there turns ON.

## TIMING CHART

Frequency display timing chart of IC702 (TC9147AP)

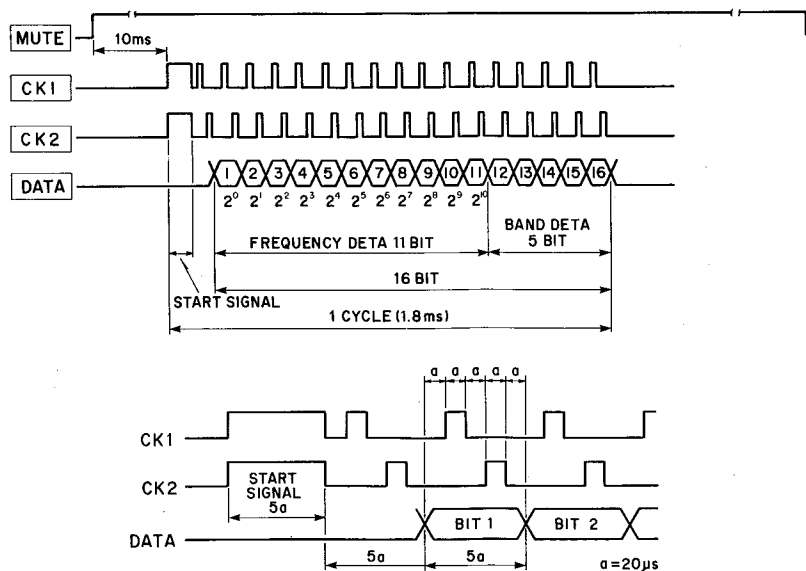

# BLOCK DIAGRAM

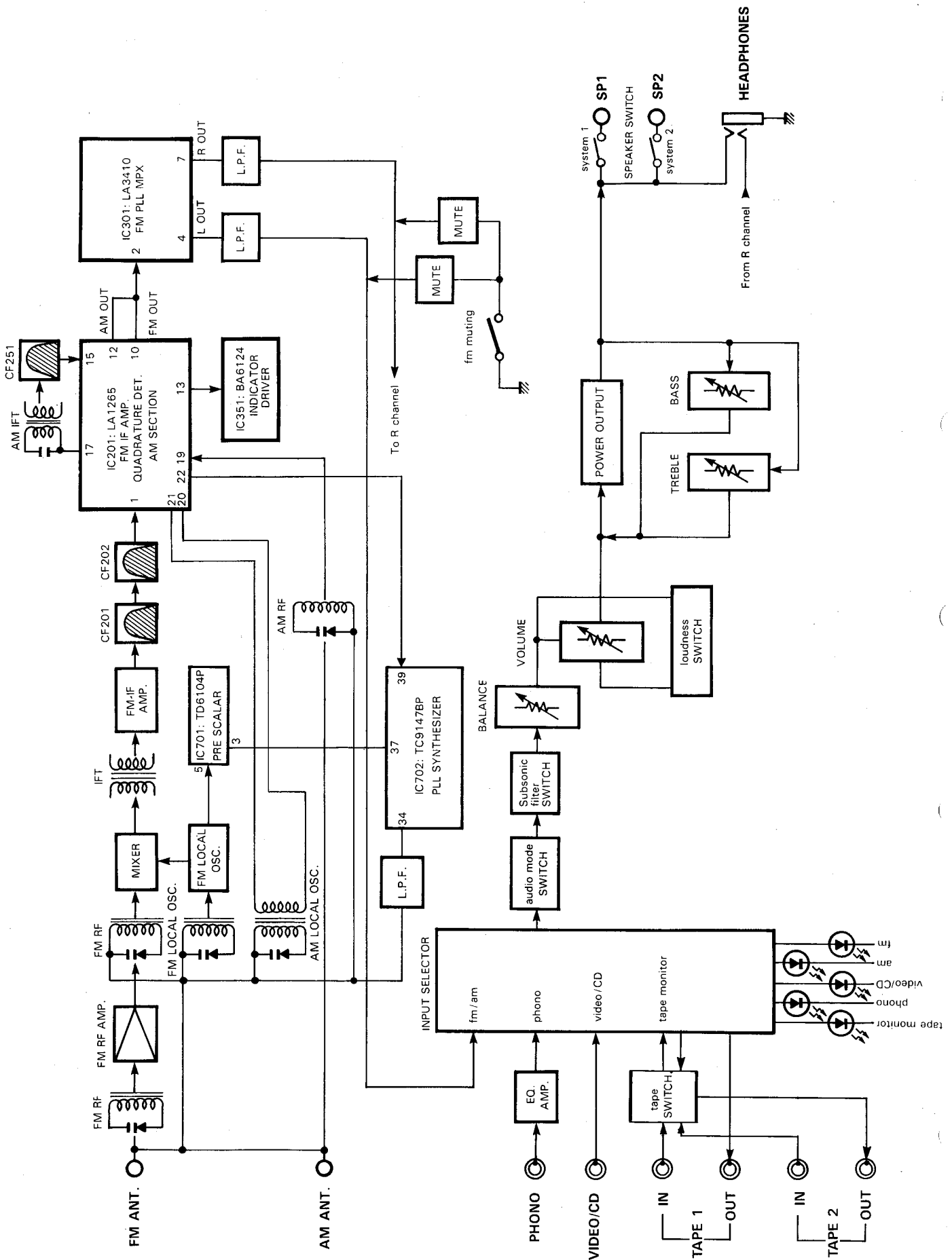



**ALIGNMENT PROCEDURES (REFER TO PAGES 9, 10, 13 AND 14)****■ IDLING ADJUSTMENT**

Conditions: ● Press the "video/CD" switch.

- Set the volume to minimum.
- Press the "SPEAKERS system 1 and 2" switches to the off (button out) position.

Step	Connection Equipments	Adjustment	For
1	● Connect the Digital Voltmeter to TP1 and TP2.	VR401 (L channel)	36mV
2	● Connect the Digital Voltmeter to TP3 and TP4.	VR402 (R channel)	36mV
3	Repeat steps 1 and 2 after aging for 15 minutes.		

**■ STANDARD FREQUENCY CHECK**

Conditions: ● Press the "fm" switch.

Step	Connection Equipments	Station Display	For
1	● Connect the Frequency Counter to TP5 and ground.	98.3MHz	109MHz $\pm$ 2kHz

**■ AM ADJUSTMENT**

Conditions: ● Press the "am" switch.

- Standard modulation of the AM Signal Generator is 400Hz at 30%.
- Connect the AM loop antenna (accessory) to the AM antenna terminal.

Step	Alignment	Connection Equipments	Measurement Frequency	Station Display	Adjustment	For
1	Tuning voltage	● Connect the Frequency Counter to TP6 and ground.		1710kHz	TC252	8V $\pm$ 0.5V
2	IF	● Connect the AM Test Loop Antenna cable into the output jack of AM Signal Generator. Place AM Test Loop Antenna close enough to couple signal into the AM Loop Antenna.	1400kHz	1400kHz	T251	Maximum output
3	Tracking		1400kHz	1400kHz	TC251	Maximum output
4			600kHz	600kHz	L251	Maximum output
5			Repeat steps 3 and 4 for optimum sensitivity.			
6	Tuned indicator	● Connect the VTVM and Oscilloscope to the Tape 1 Out jacks.	1000kHz	1000kHz		Confirm the Tuned indicator lights at 74dB $\mu$ V/m input.

## FM ADJUSTMENT

- Conditions:
- Press the "fm" switch.
  - Press the "fm muting" switch to the "off" position.
  - Press the "audio mode" switch to the stereo (button out) position.

<b>FM Signal Generator</b>	1kHz, 100% modulation
<b>Stereo Modulator</b>	L + R = 45.5%, L - R = 45.5%, 19kHz = 9%

Step	Alignment	Connection Equipments	Measurement Frequency	Station Display	Adjustment	For
1	Discriminator	<ul style="list-style-type: none"> <li>• Connect the FM Signal Generator to FM 300Ω BAL Antenna terminals through the 300Ω balanced dummy.</li> <li>• Connect the Distortion meter and Oscilloscope to the Tape 1 Out jacks.</li> </ul>	98.1MHz ± 30 ~ 40kHz	98.1MHz	T201(A)	Adjust so that the Tuned indicator lights in the same range on both plus (+) and minus (-) sides of 98.1MHz.
2			98.1MHz	98.1MHz	T201(B)	Minimum distortion
3			Repeat steps 1 and 2 for optimum sensitivity.			
4	Tuned indicator			98.1MHz	VR201	Adjust so that the Tuned indicator lights at 20μV input.
5	Signal Strength indicator			98.1MHz	VR202	Adjust so that the three Signal Strength indicator lights at 50μV input.
6	Separation	<ul style="list-style-type: none"> <li>• Connect the Stereo Modulator to FM Signal Generator. Connect FM Signal Generator to FM 300Ω BAL Antenna terminals through the 300Ω balanced dummy.</li> <li>• Connect the VTVM and Oscilloscope to the Tape 1 Out jacks.</li> </ul>	98.1MHz	98.1MHz	VR301	Adjust so that the right channel output becomes minimum when only the left channel of the Stereo Modulator modulated.
					VR301	Adjust so that the left channel output becomes minimum when only the right channel of the Stereo Modulator modulated.

**SCHEMATIC DIAGRAM (1)**

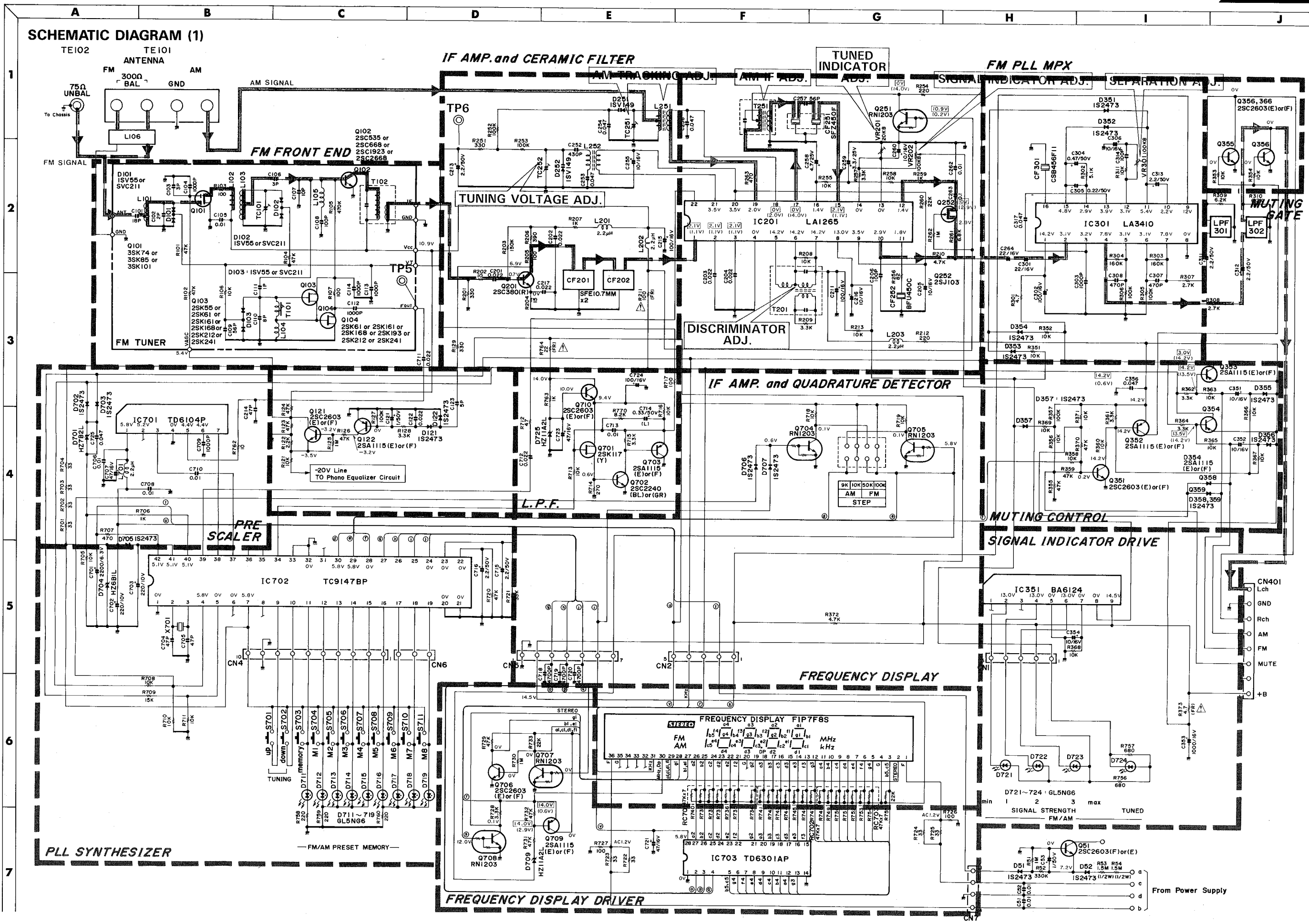

# SCHEMATIC DIAGRAM (1)

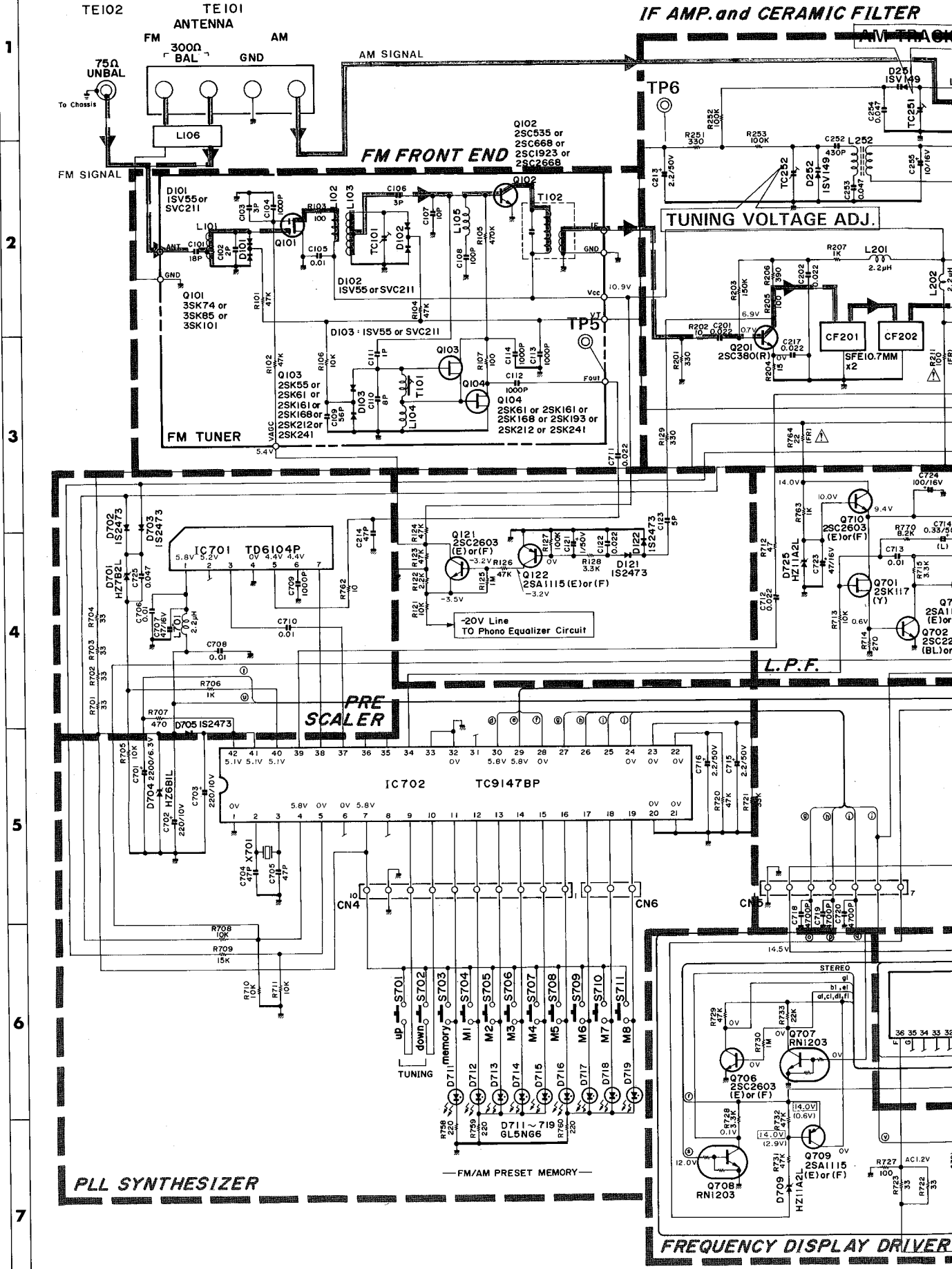

F G H I J

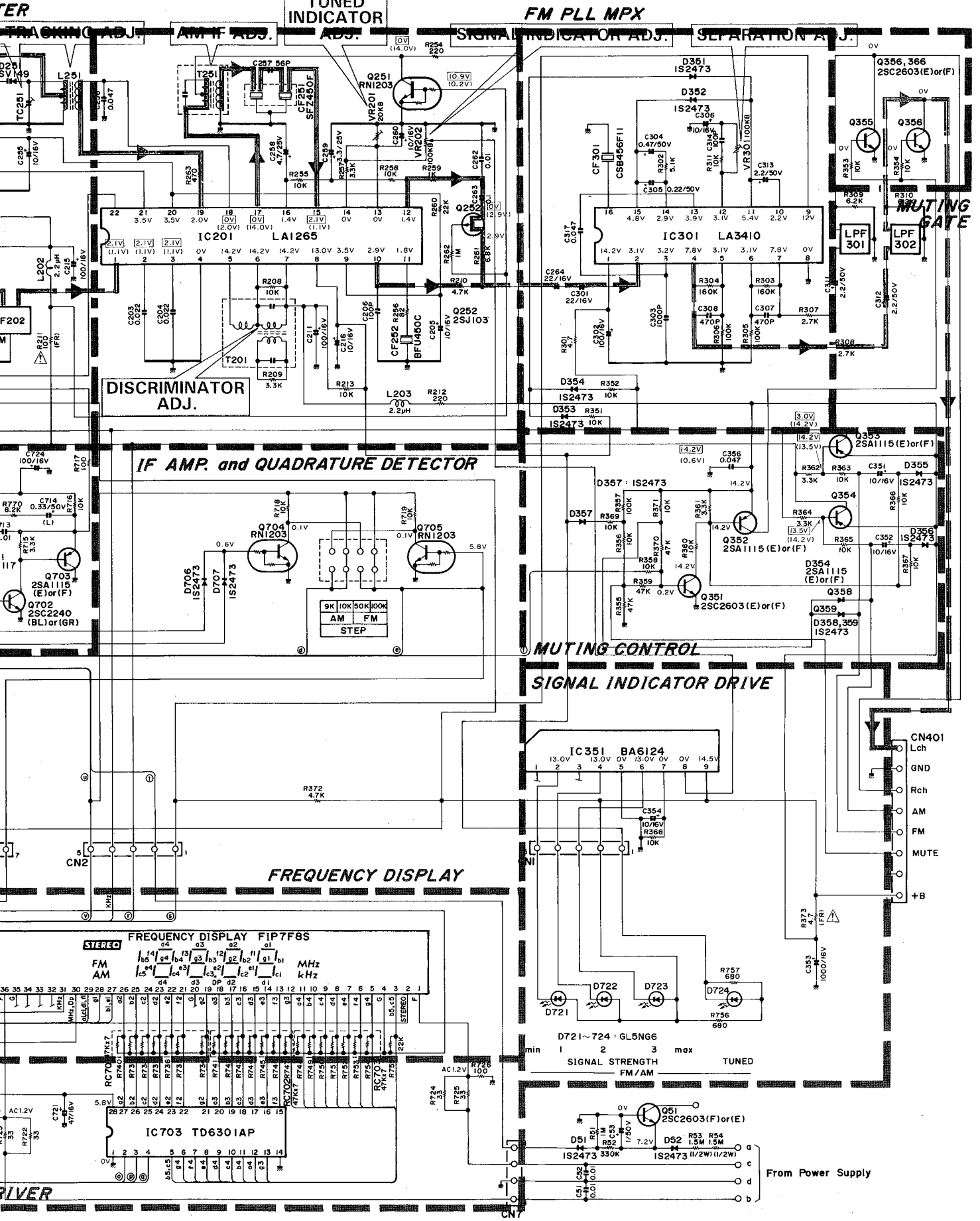

SCHEMATIC DIAGRAM (2)

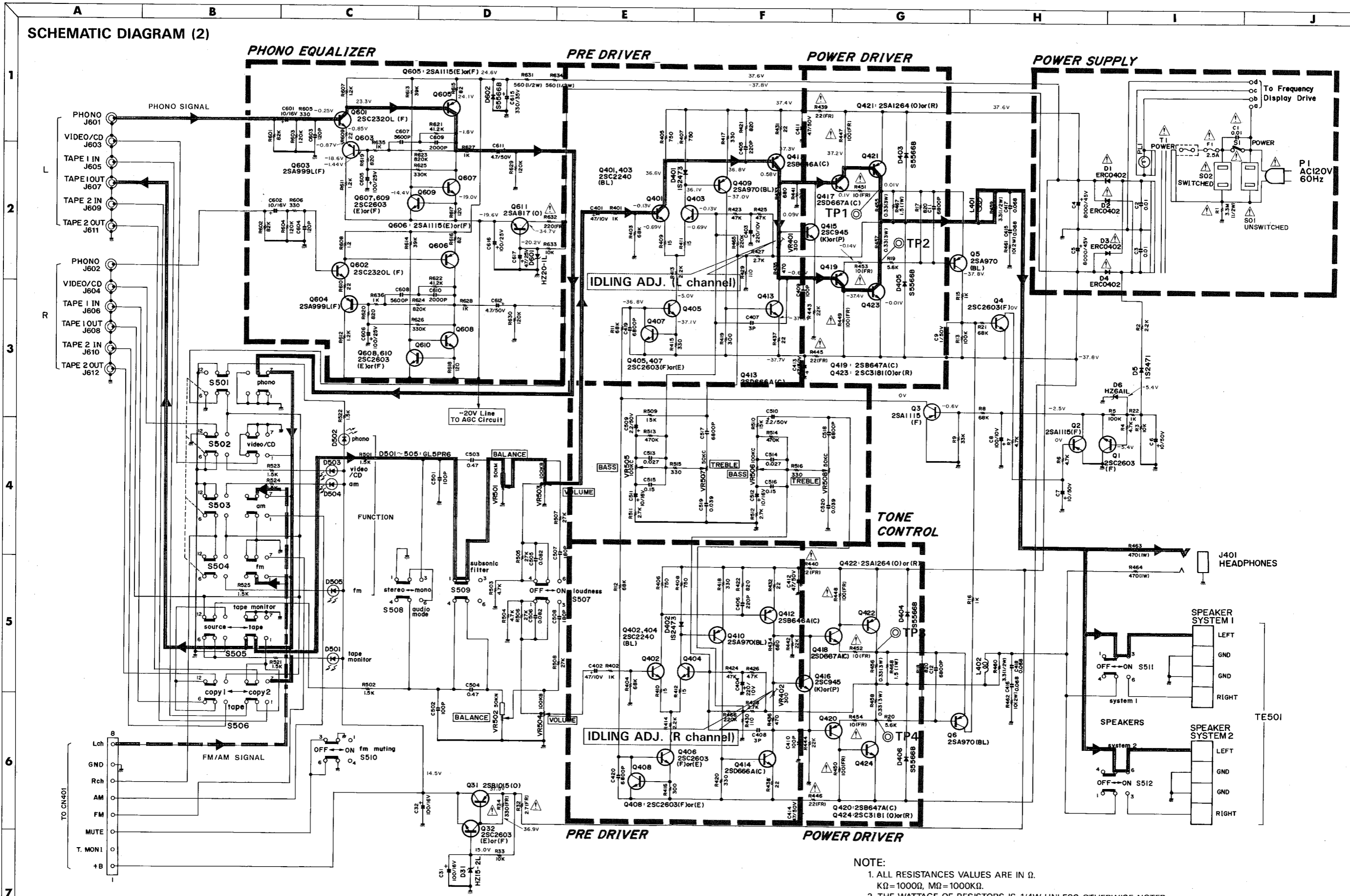

- NOTE:
1. ALL RESISTANCES VALUES ARE IN  $\Omega$ .  
K $\Omega$ =1000 $\Omega$ , M $\Omega$ =1000K $\Omega$ .
  2. THE WATTAGE OF RESISTORS IS 1/4W UNLESS OTHERWISE NOTED.
  3. ALL CAPACITANCES VALUES ARE IN  $\mu$ F UNLESS OTHERWISE NOTED. P= $\mu$ F
  4. V: DC VOLTAGE AT NO SIGNAL  
 (...V) FM POSITION  
 (...V) AM POSITION
  5. SAFETY REQUIREMENTS COMPONENTS IN ACCORDANCE WITH PRESENT SAFETY REGULATIONS, THESE COMPONENTS MUST ONLY BE REPLACED BY ORIGINAL PARTS.

SCHMATIC DIAGRAM (2)

PHONO EQUALIZER

PRE DRIVER

1

2

3

4

5

6

7

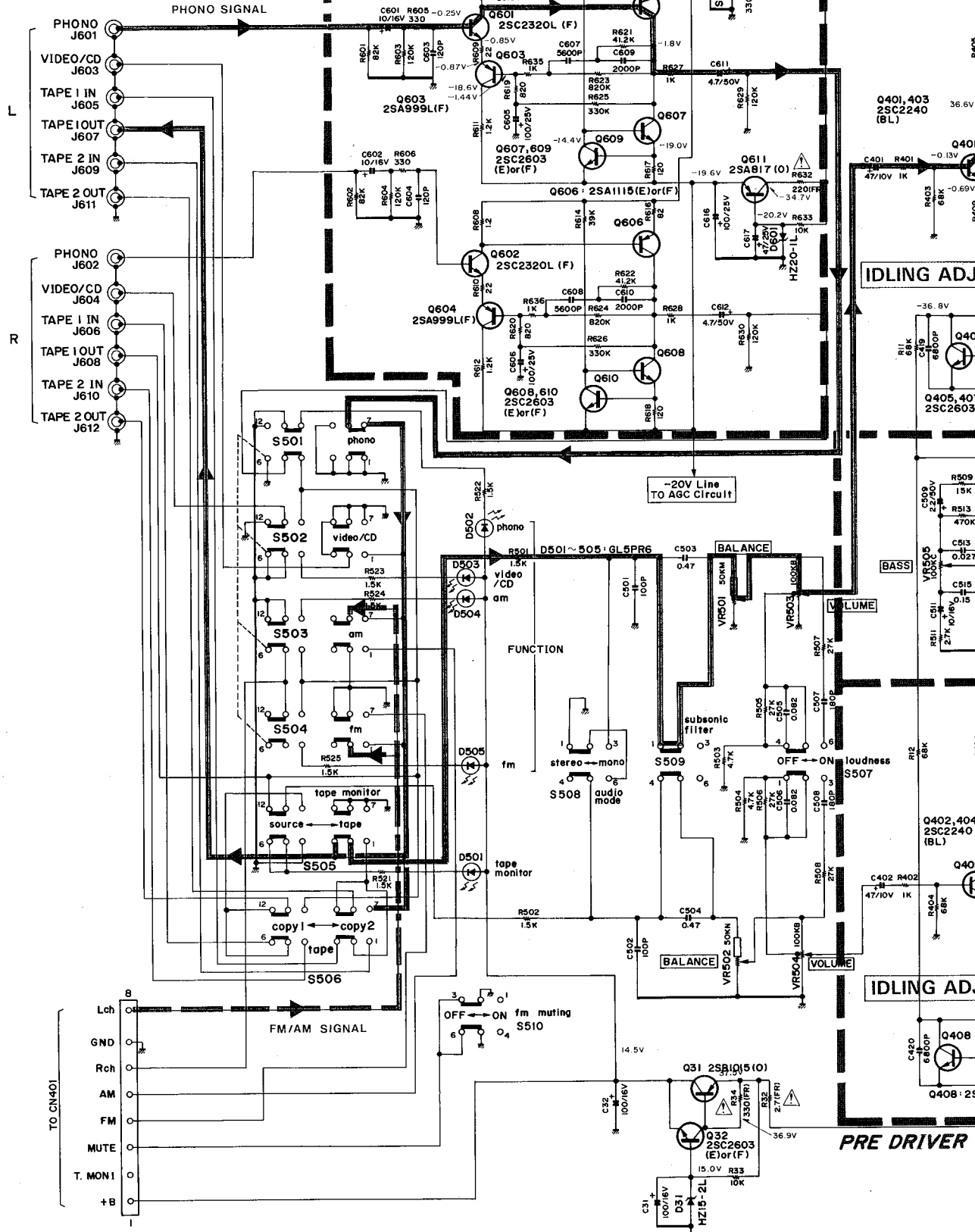

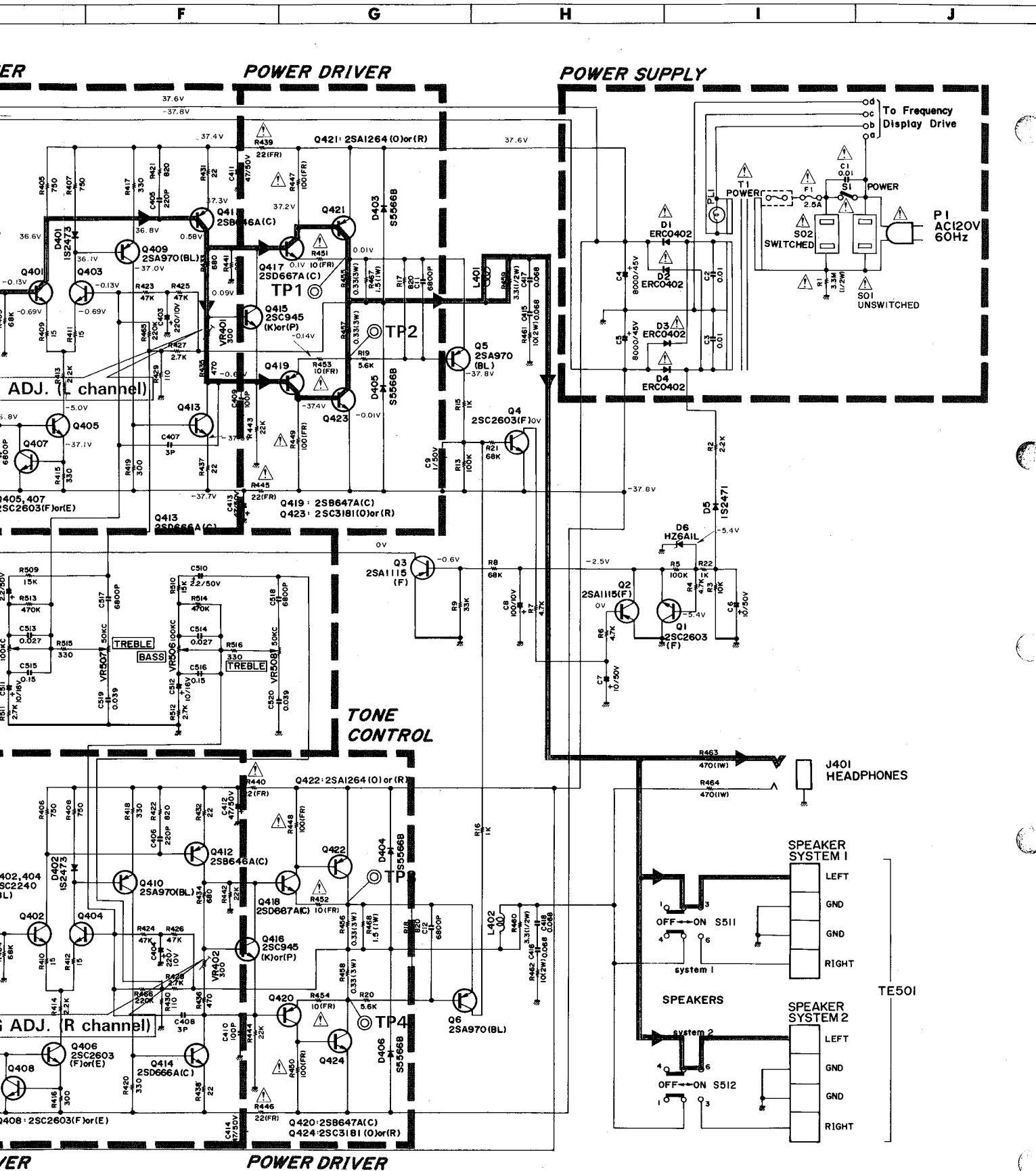

**NOTE:**

1. ALL RESISTANCES VALUES ARE IN  $\Omega$ .  
 $K\Omega = 1000\Omega$ ,  $M\Omega = 1000K\Omega$ .
2. THE WATTAGE OF RESISTORS IS 1/4W UNLESS OTHERWISE NOTED.
3. ALL CAPACITANCES VALUES ARE IN  $\mu F$  UNLESS OTHERWISE NOTED.  $P = \mu\mu F$
4. V: DC VOLTAGE AT NO SIGNAL  
 $\dots V$  FM POSITION  
 $(\dots V)$  AM POSITION
5.  SAFETY-REQUIREMENTS COMPONENTS IN ACCORDANCE WITH PRESENT SAFETY REGULATIONS, THESE COMPONENTS MUST ONLY BE REPLACED BY ORIGINAL PARTS.



IC BLOCK DIAGRAM

IC201: LA1265

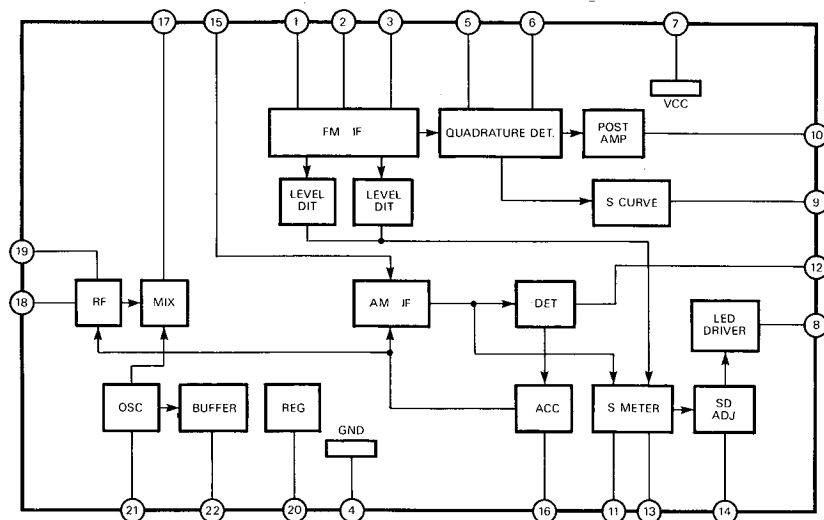

IC301: LA3410

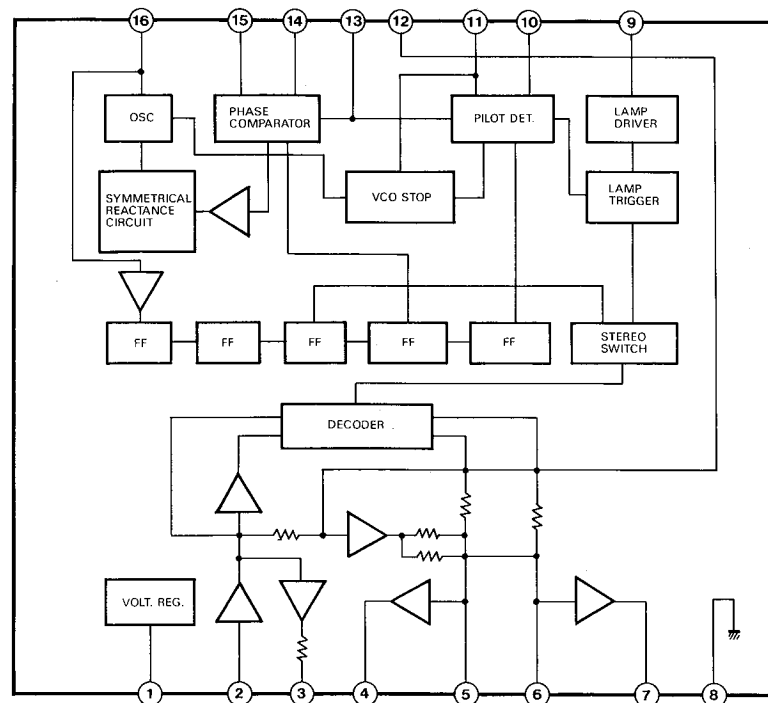

IC351: BA6124

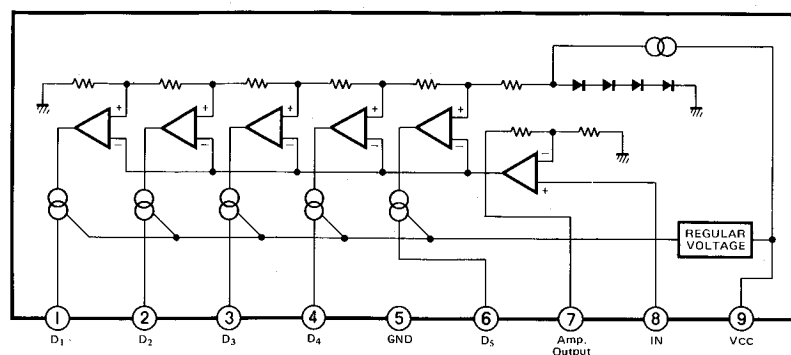

IC701: TD6104P

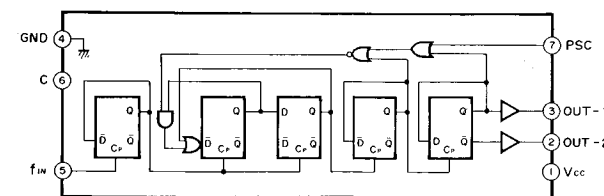

IC702: TC9147BP

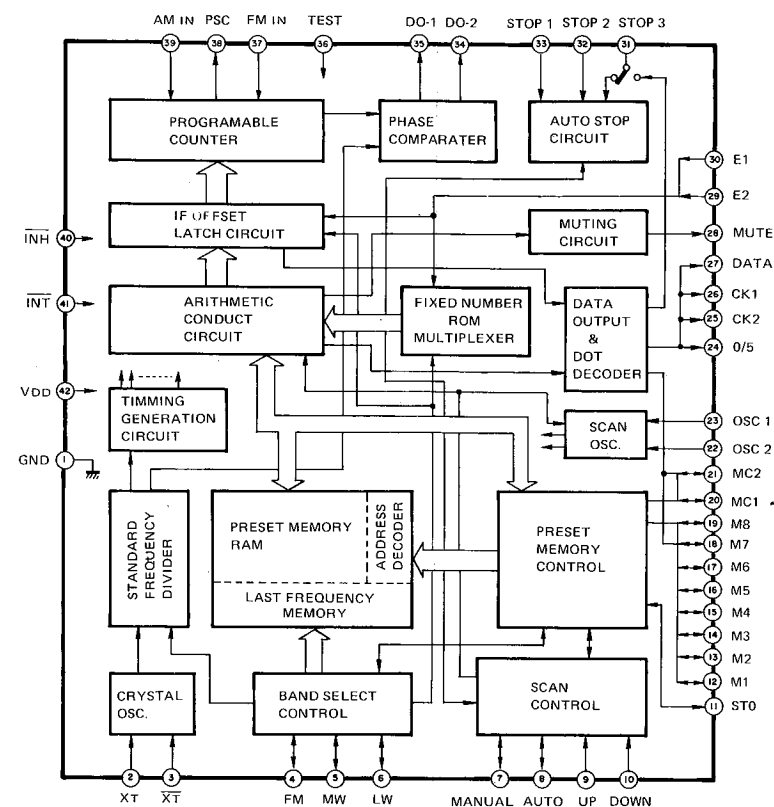

IC703: TD6301AP

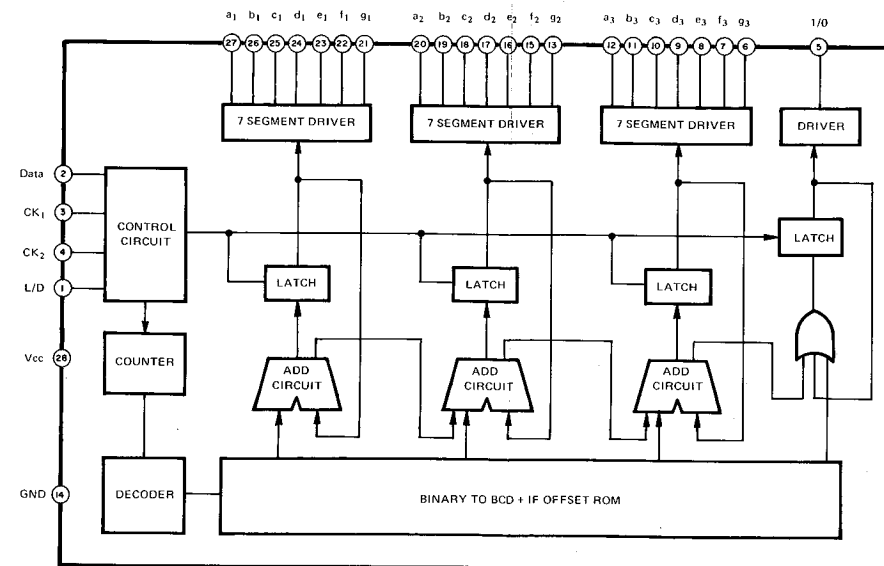

# IC BLOCK DIAGRAM

IC201: LA1265

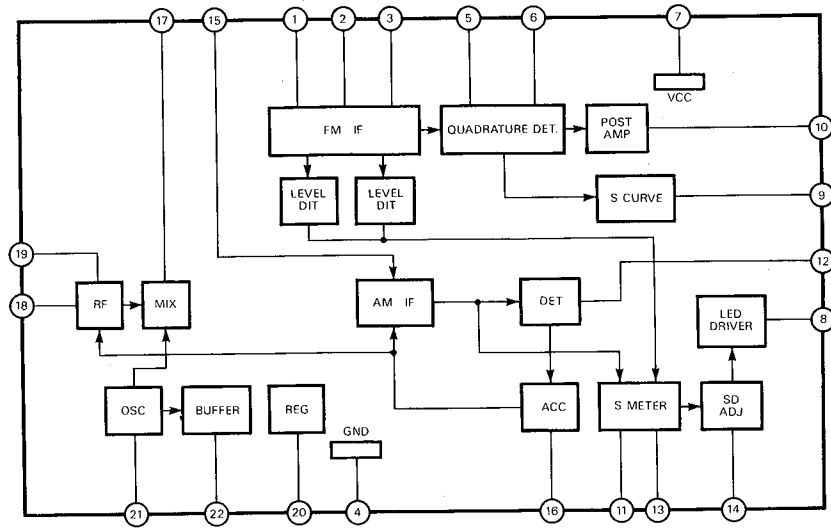

IC301: LA3410

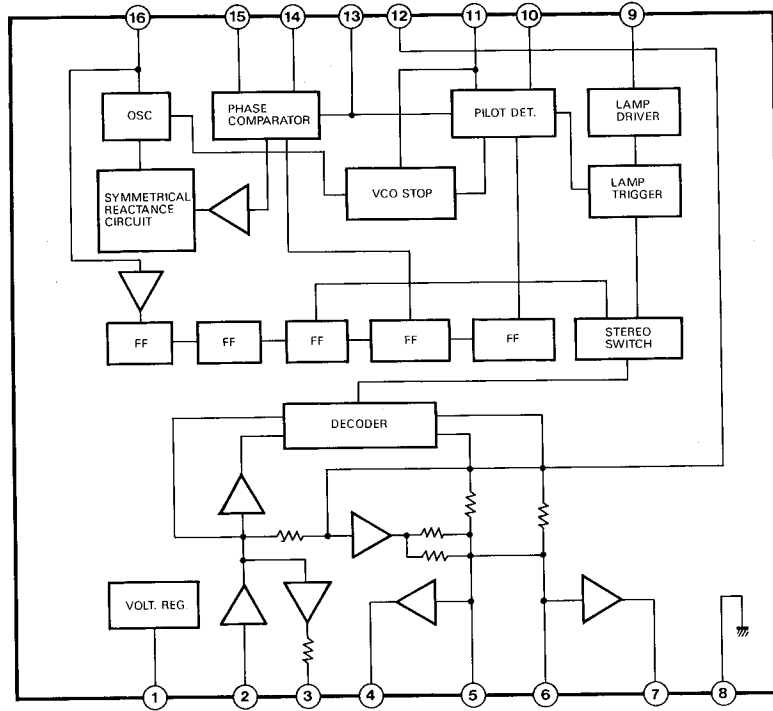

IC351: BA6124

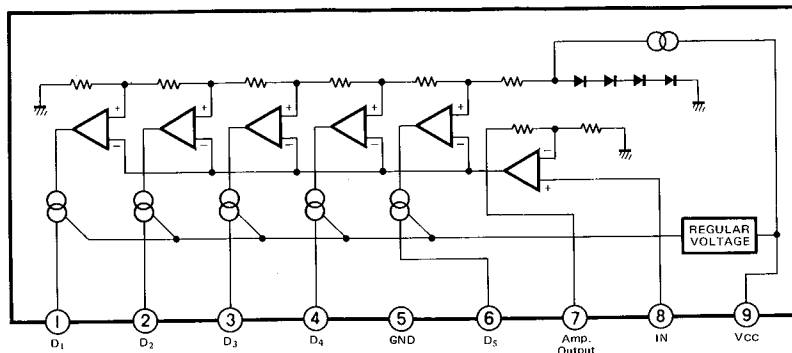

IC701: TD6104P

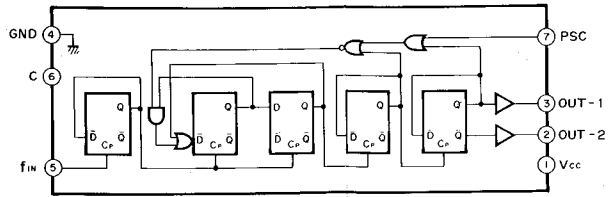

IC702: TC9147BP

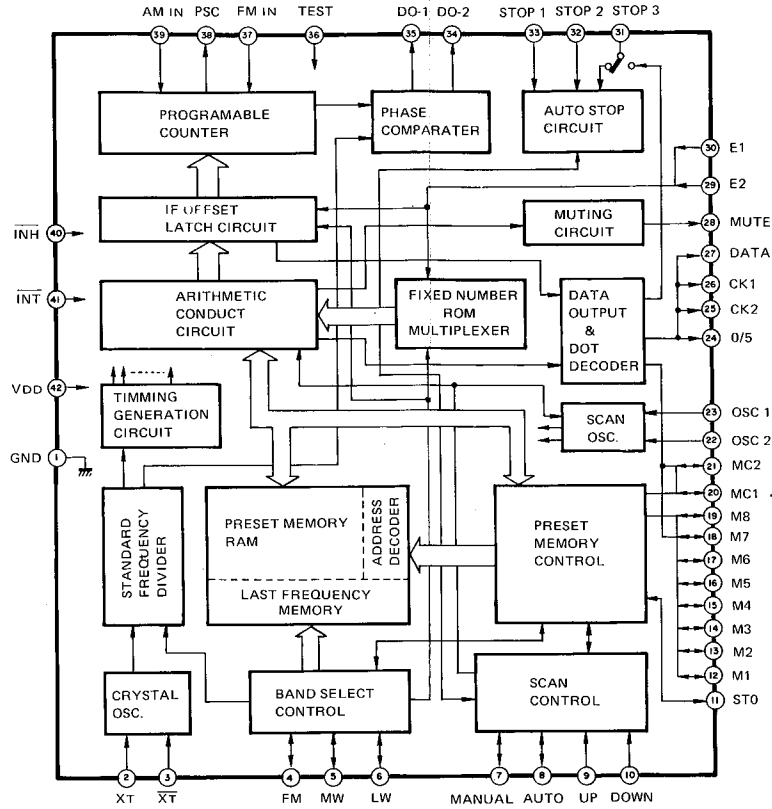

IC703: TD6301AP

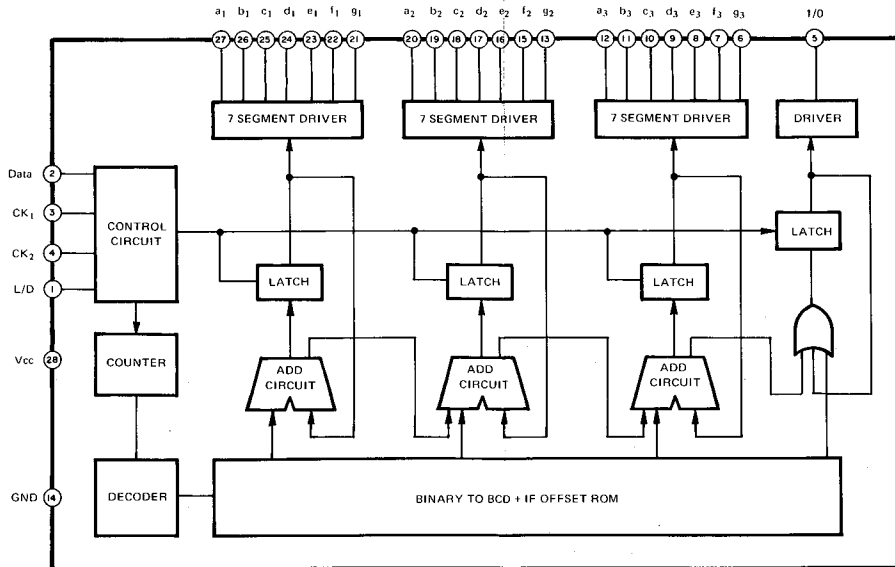

# WIRING DIAGRAM

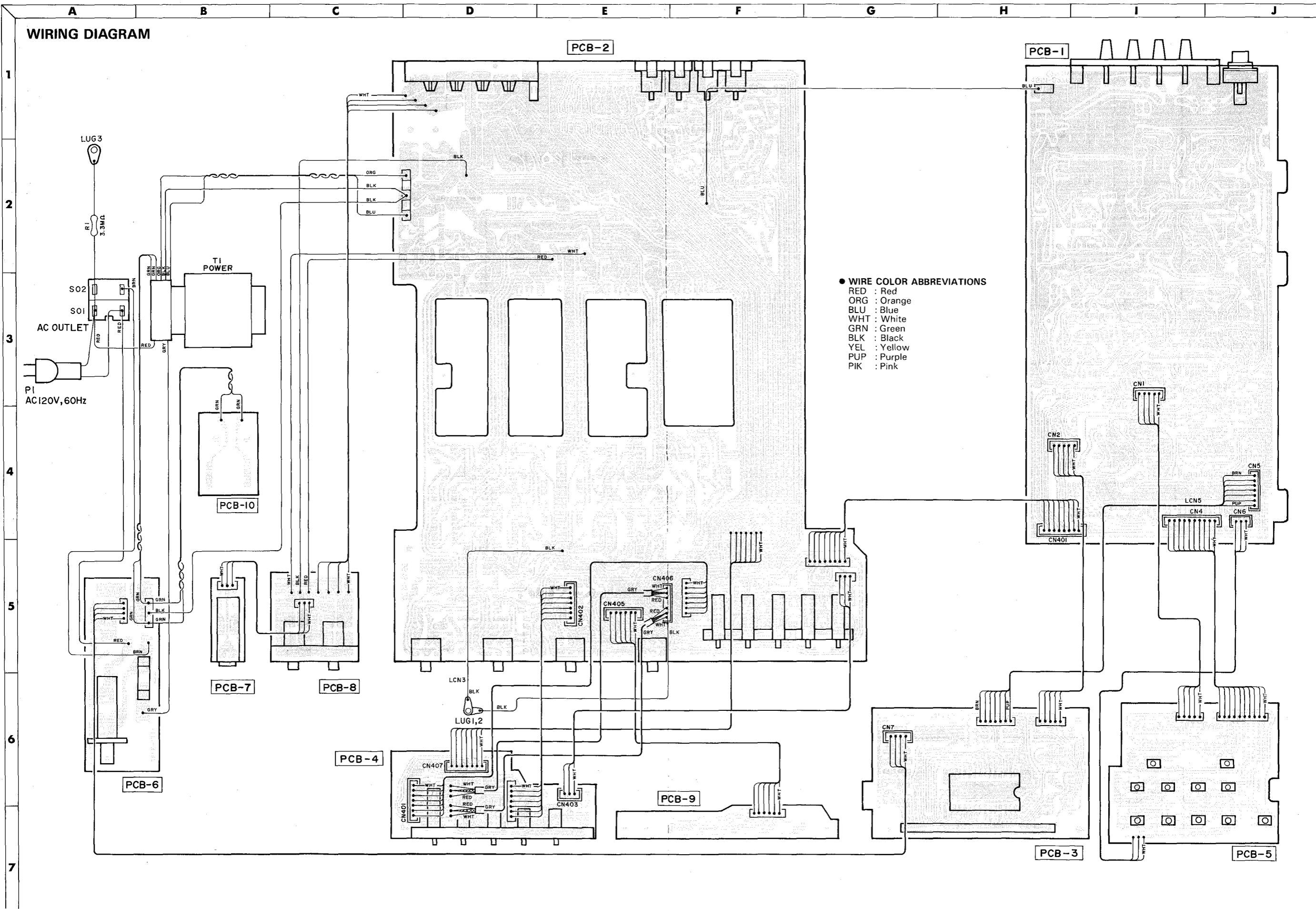

- WIRE COLOR ABBREVIATIONS
- RED : Red
  - ORG : Orange
  - BLU : Blue
  - WHT : White
  - GRN : Green
  - BLK : Black
  - YEL : Yellow
  - PUP : Purple
  - PIK : Pink

# WIRING DIAGRAM

PCB-2

1  
2  
3  
4  
5  
6  
7

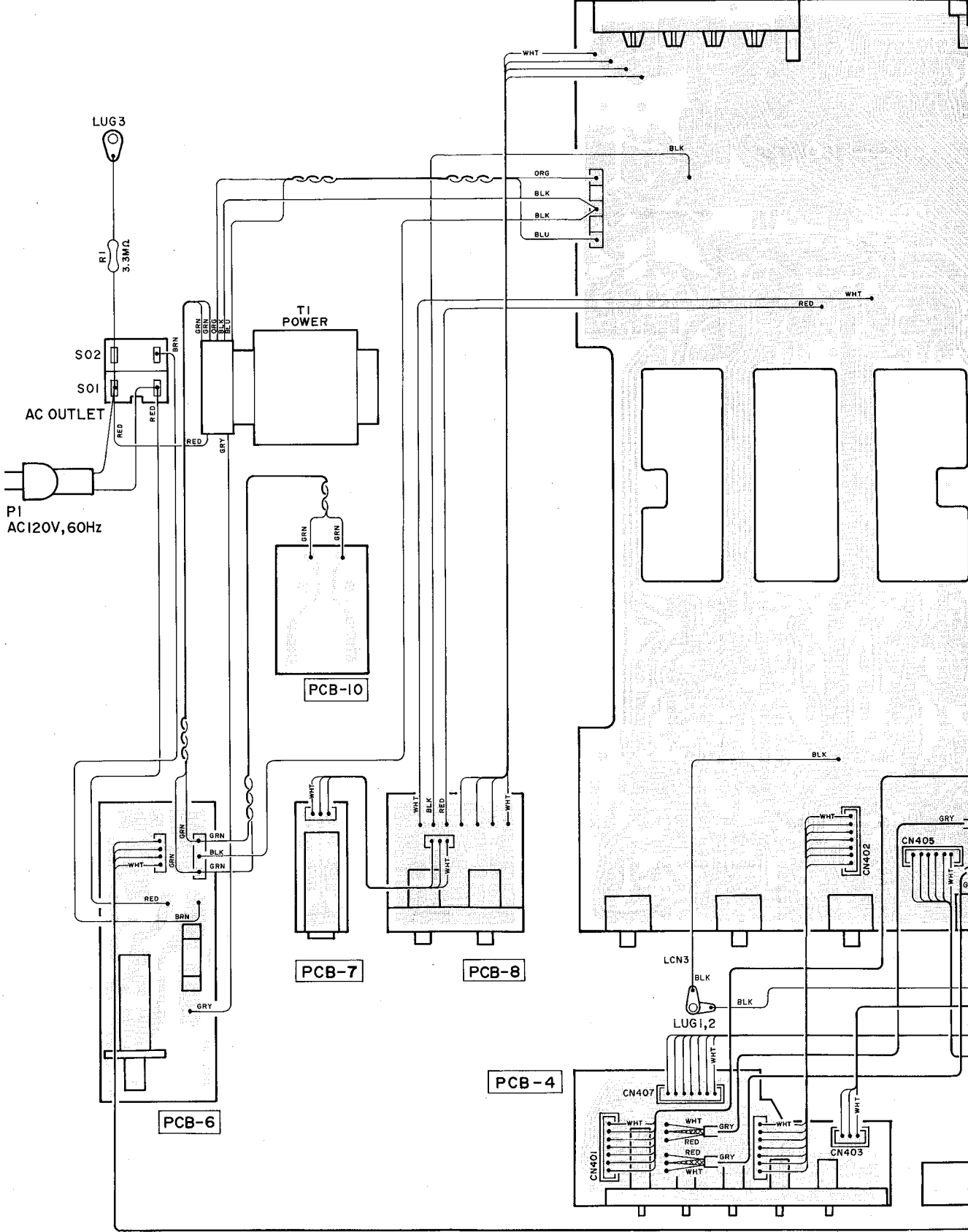

F

G

H

I

J

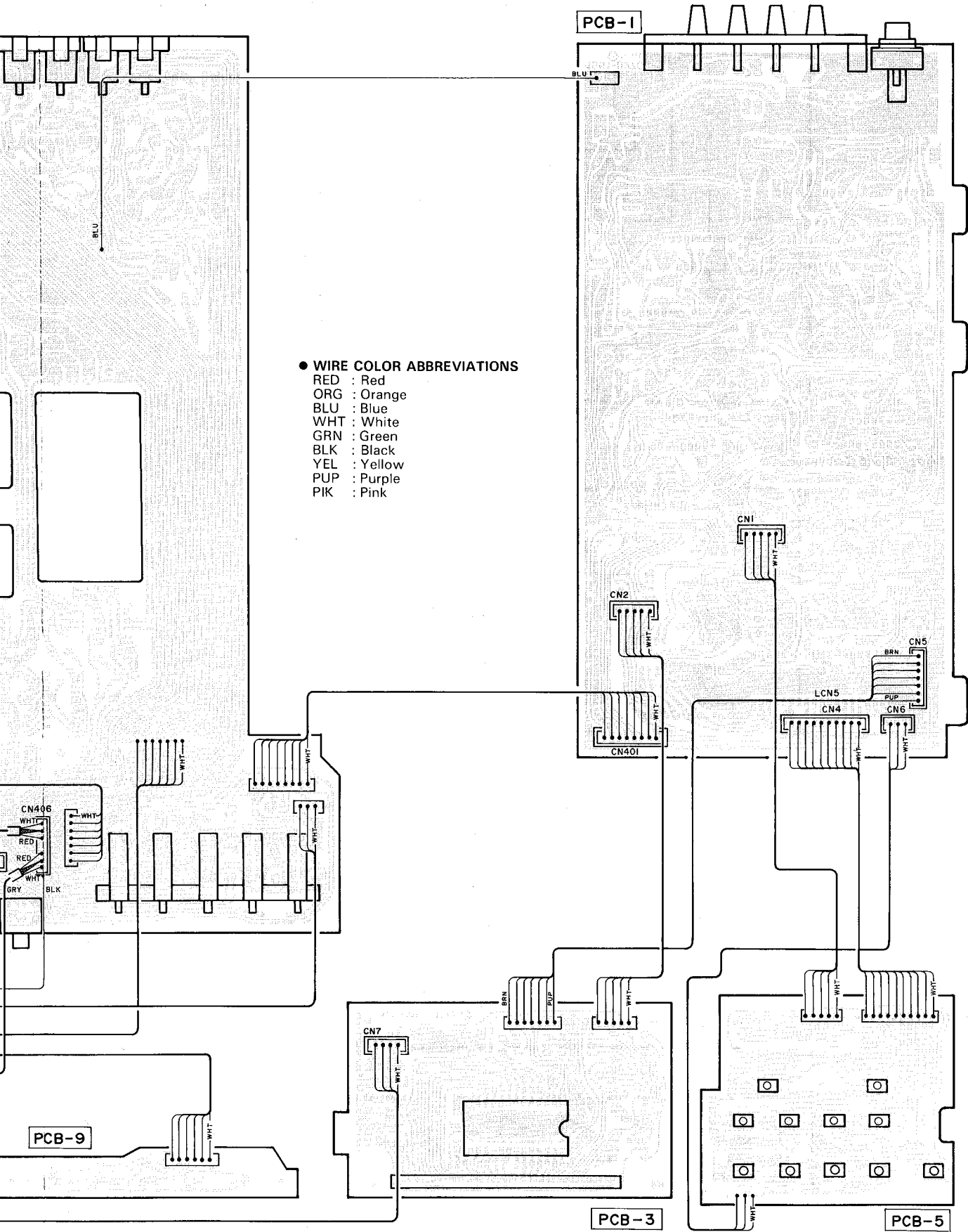

● WIRE COLOR ABBREVIATIONS

- RED : Red
- ORG : Orange
- BLU : Blue
- WHT : White
- GRN : Green
- BLK : Black
- YEL : Yellow
- PUP : Purple
- PIK : Pink

PCB-1

BLU

CN1

CN2

CN401

CN5

LCN5

CN4

CN6

CN406

WHT

RED

RED

GRY

WHT

BLK

CN7

WHT

BRN

PUP

WHT

PCB-9

PCB-3

PCB-5

P. C. BOARDS (1)

PCB-1 Tuner P. C. Board

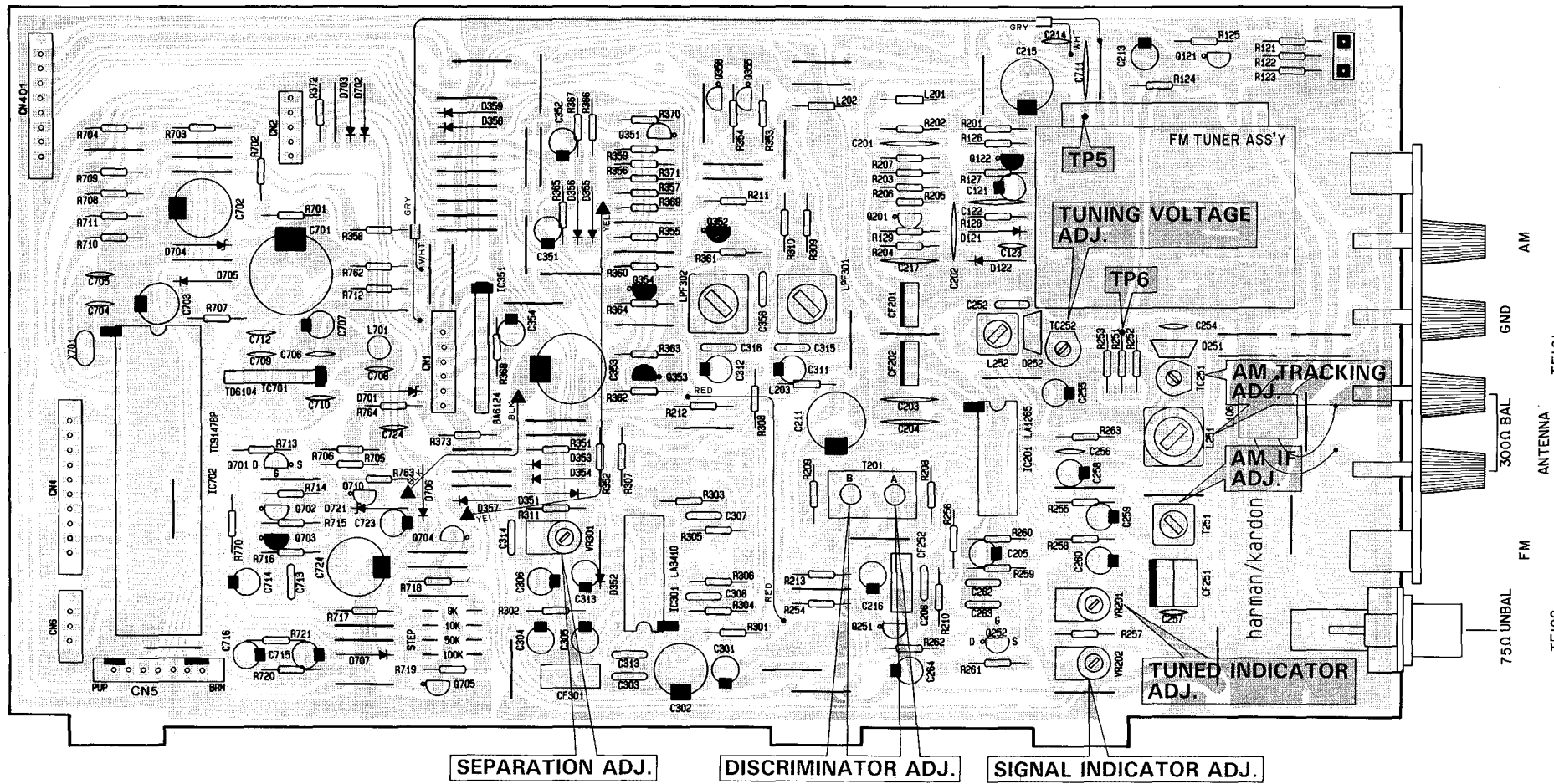

PCB-6 Power Switch P. C. Board

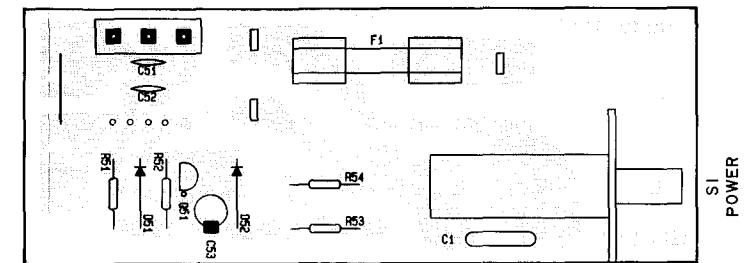

PCB-5 Tact Switches P. C. Board

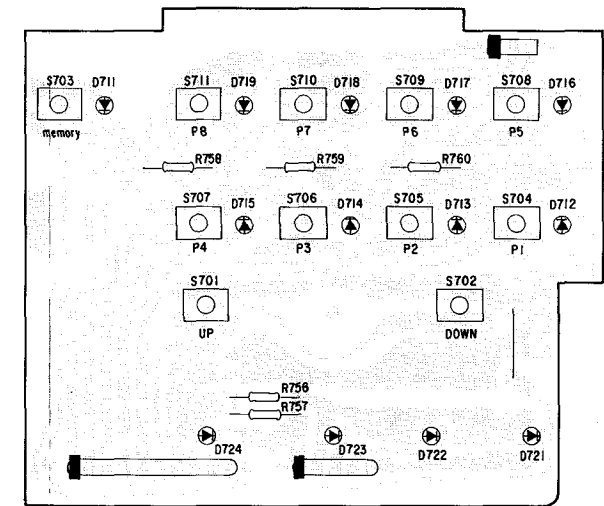

PCB-3 Frequency Display P. C. Board

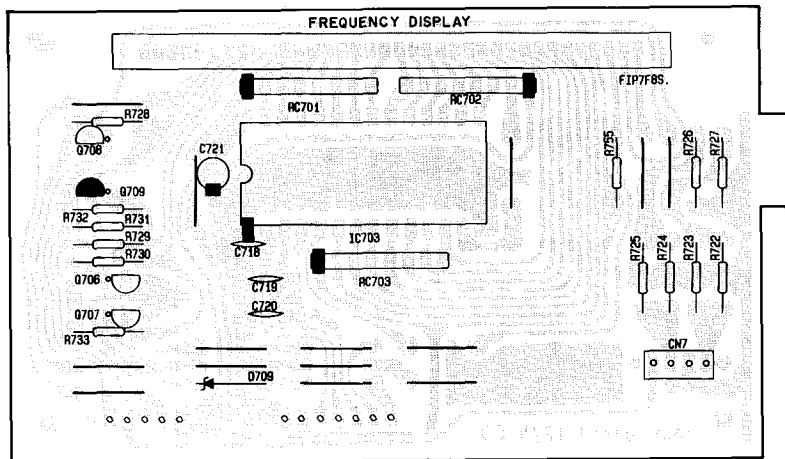

PCB-4 Push Switches P. C. Board

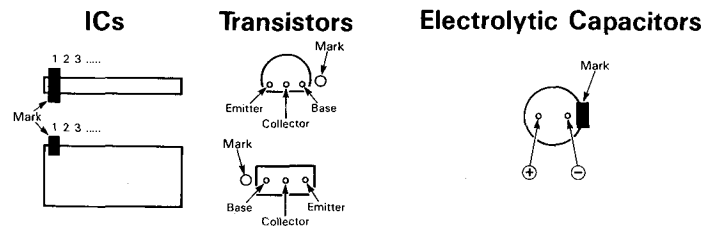
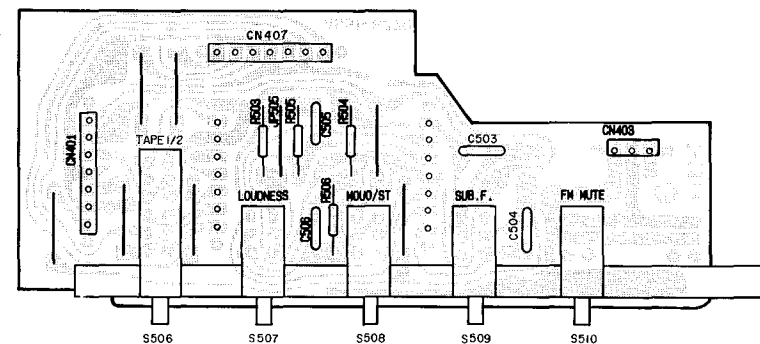

PIN CONNECTION DIAGRAM OF TRANSISTORS, DIODES AND ICs.

2SA970 2SB648 2SD668 2SC945 2SD667A 2SB647A 2SC2320L 2SC2240	2SA999L 2SA817	2SC2603 2SA1115 RN1203	2SC380	2SA1265 2SC3182	2SB1015	2SJ103	2SK117	1SV149	1S2473 ERC102FL 1S2471 HZ6A1L HZ15-2L S5566B HZ20-1L HZ7B2L HZ6B1L	HZ11A2L	GL5NG6 GL5PR6	BA6124	LA3410	LA1265	TD6104P	TD6301AP	TC9147BP

P. C. BOARDS (1)

PCB-1 Tuner P. C. Board

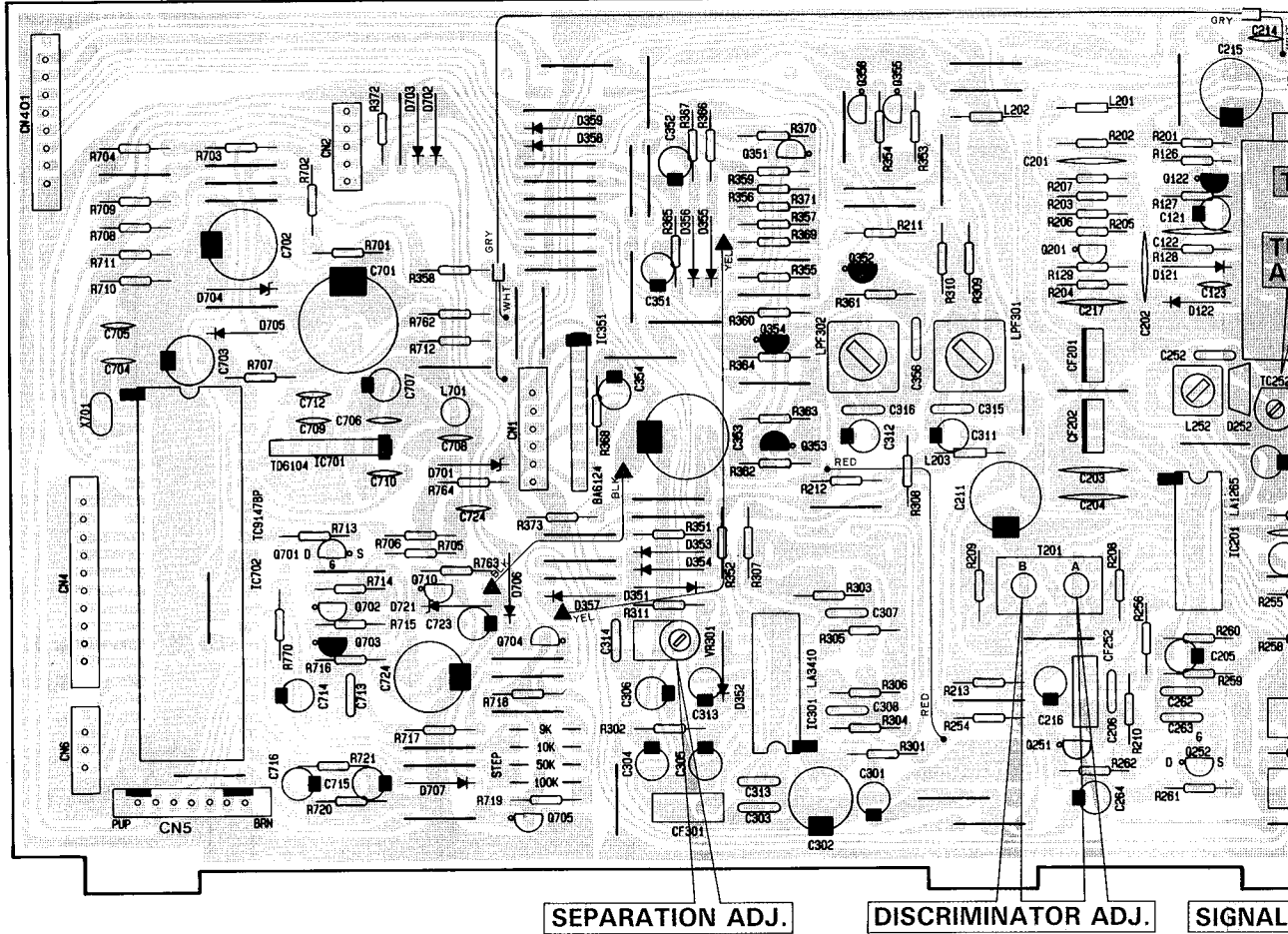

PCB-3 Frequency Display P. C. Board

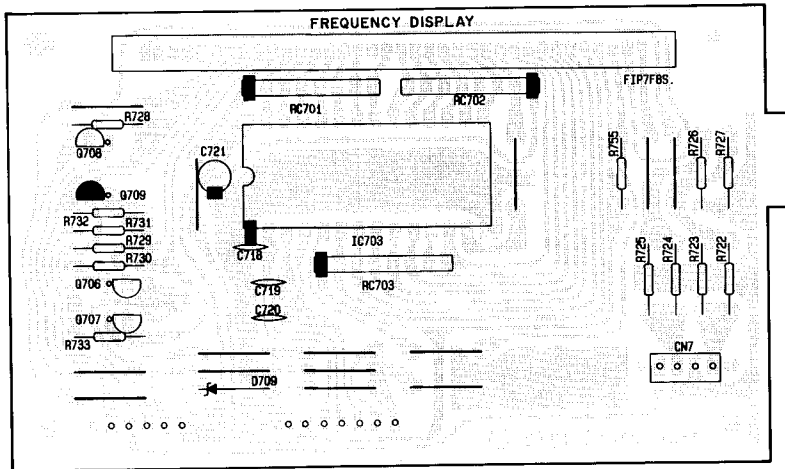

PCB-4 Push Switch

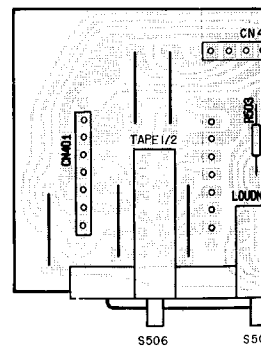

PIN CONNECTION DIAGRAM OF TRANSISTORS, DIODES AND ICS.

<p>2SA970 2SB648 2SD668 2SC945 2SD667A 2SB647A 2SC2320L 2SC2240</p>	<p>2SA999L 2SA817</p>	<p>2SC2603 2SA1115 RN1203</p>	<p>2SC380</p>	<p>2SA1265 2SC3182</p>	<p>2SB1015</p>	<p>2SJ103</p>	<p>2SK117</p>	<p>1SV149</p>	<p>1S247 ERC10 1S247 HZ6A1 HZ15-2 S5566 HZ20-1 HZ782 HZ6B1</p>
-------------------------------------------------------------------------------------------------	---------------------------	---------------------------------------	---------------	----------------------------	----------------	---------------	---------------	---------------	------------------------------------------------------------------------------------------------



E F G H I J

**PCB-6 Power Switch P. C. Board**

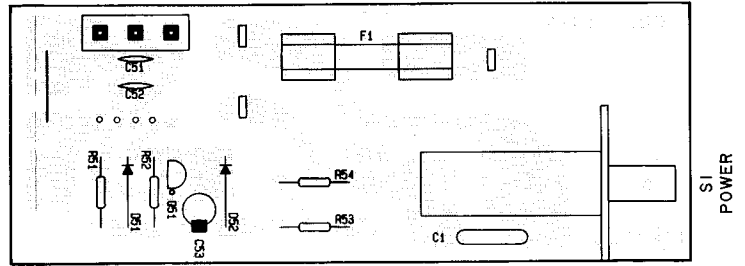

**PCB-5 Tact Switches P. C. Board**

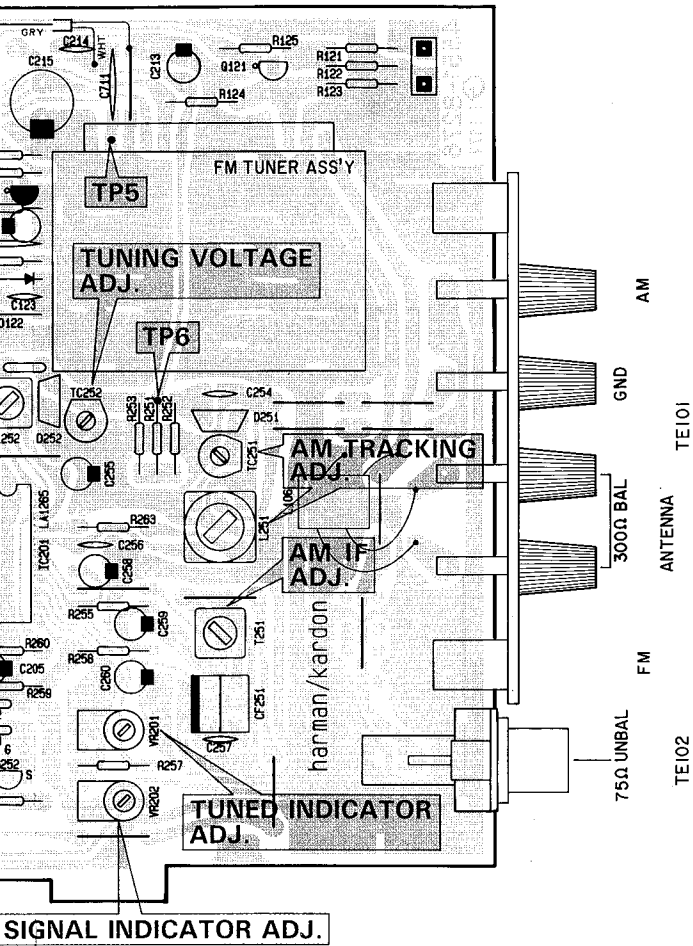
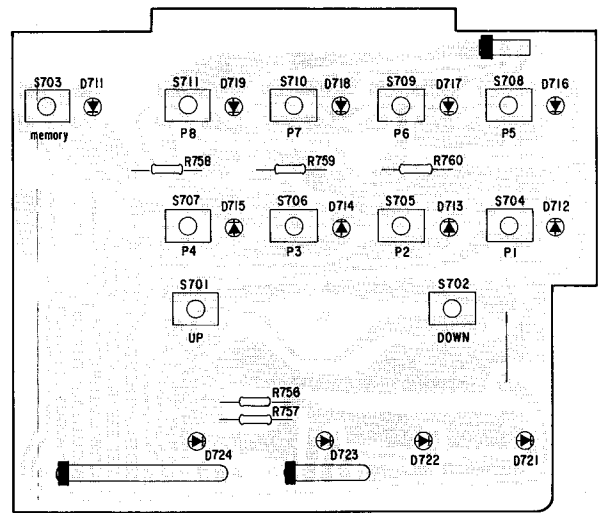

**Switches P. C. Board**

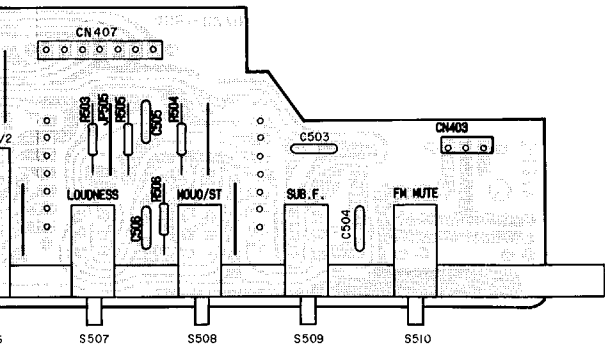

**ICs**

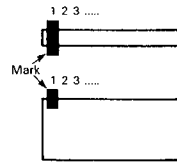

**Transistors**

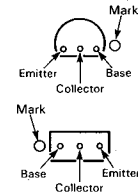

**Electrolytic Capacitors**

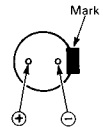

<p>1S2473 HZ11A2L ERC 102FL 1S2471 HZ6A 1L HZ15-2L S5566B HZ20-1L HZ7B2L HZ6B 1L</p> <p>Anode Cathode DIODE</p>	<p>GL5NG6 GL5PR6</p> <p>Cathode Anode</p>	<p>BA6124</p>	<p>LA3410</p>	<p>LA1265</p>	<p>TD6104P</p>	<p>TD6301AP</p>	<p>TC9147BP</p>
---------------------------------------------------------------------------------------------------------------------------------------------------------	---------------------------------------------------	---------------	---------------	---------------	----------------	-----------------	-----------------

P. C. BOARDS (2)

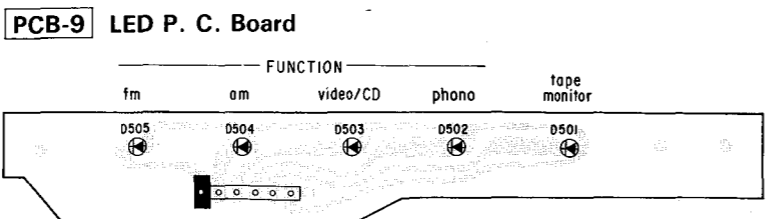

**PCB-7 Headphone Jack P. C. Board**

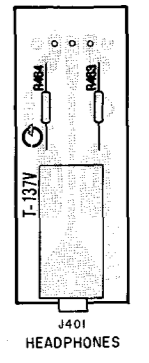

**PCB-8 Speaker Switches P. C. Board**

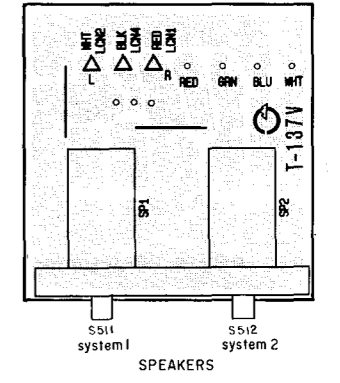

**PCB-10 Lamp P. C. Board**

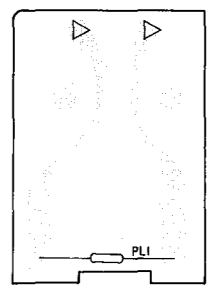

**PCB-2 Power AMP. P. C. Board**

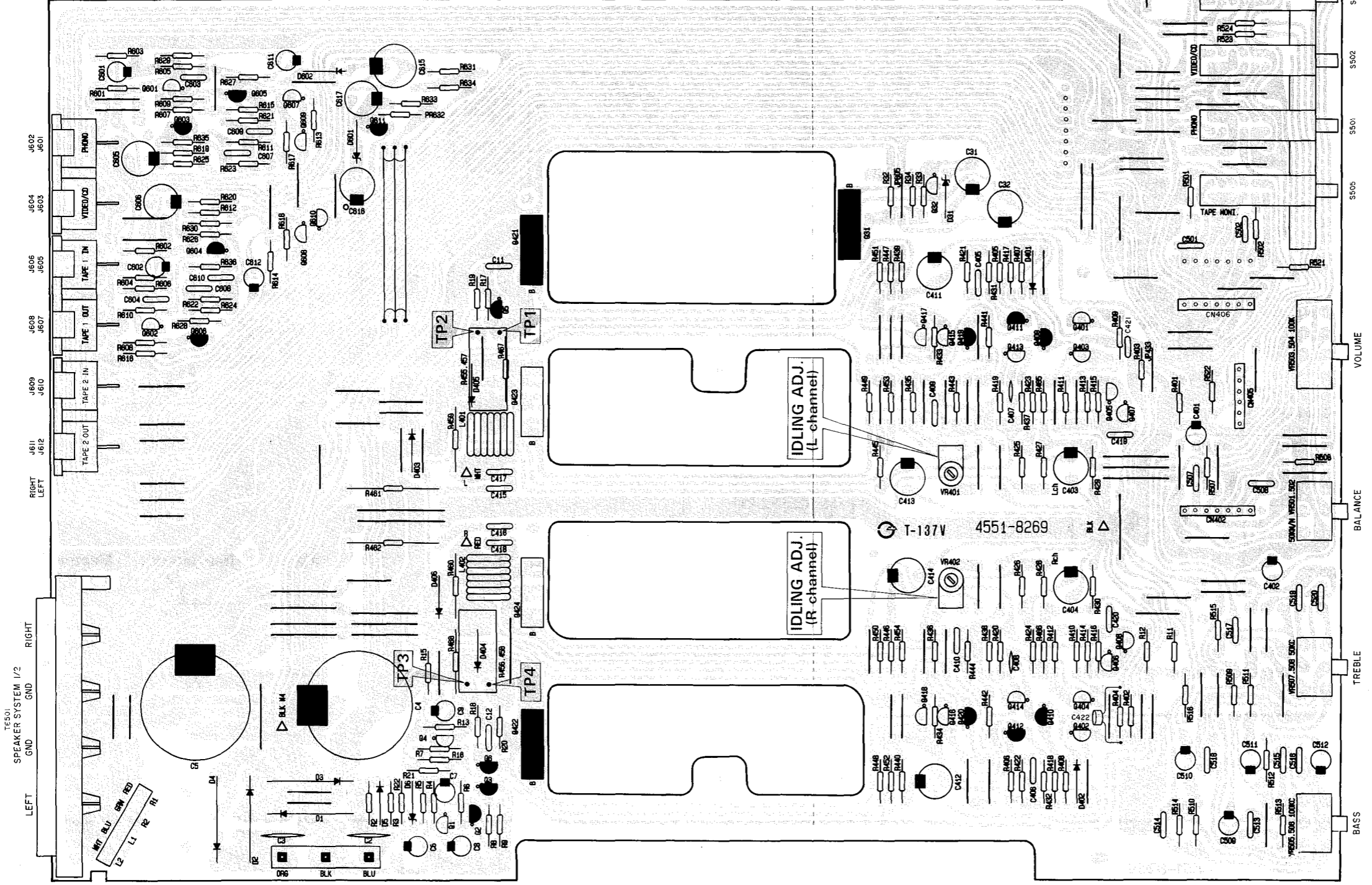

1  
2  
3  
4  
5  
6  
7

P. C. BOARDS (2)

PCB-9 LED P. C. Board

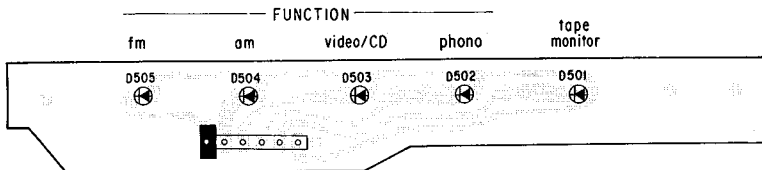

PCB-2 Power AMP. P. C. Board

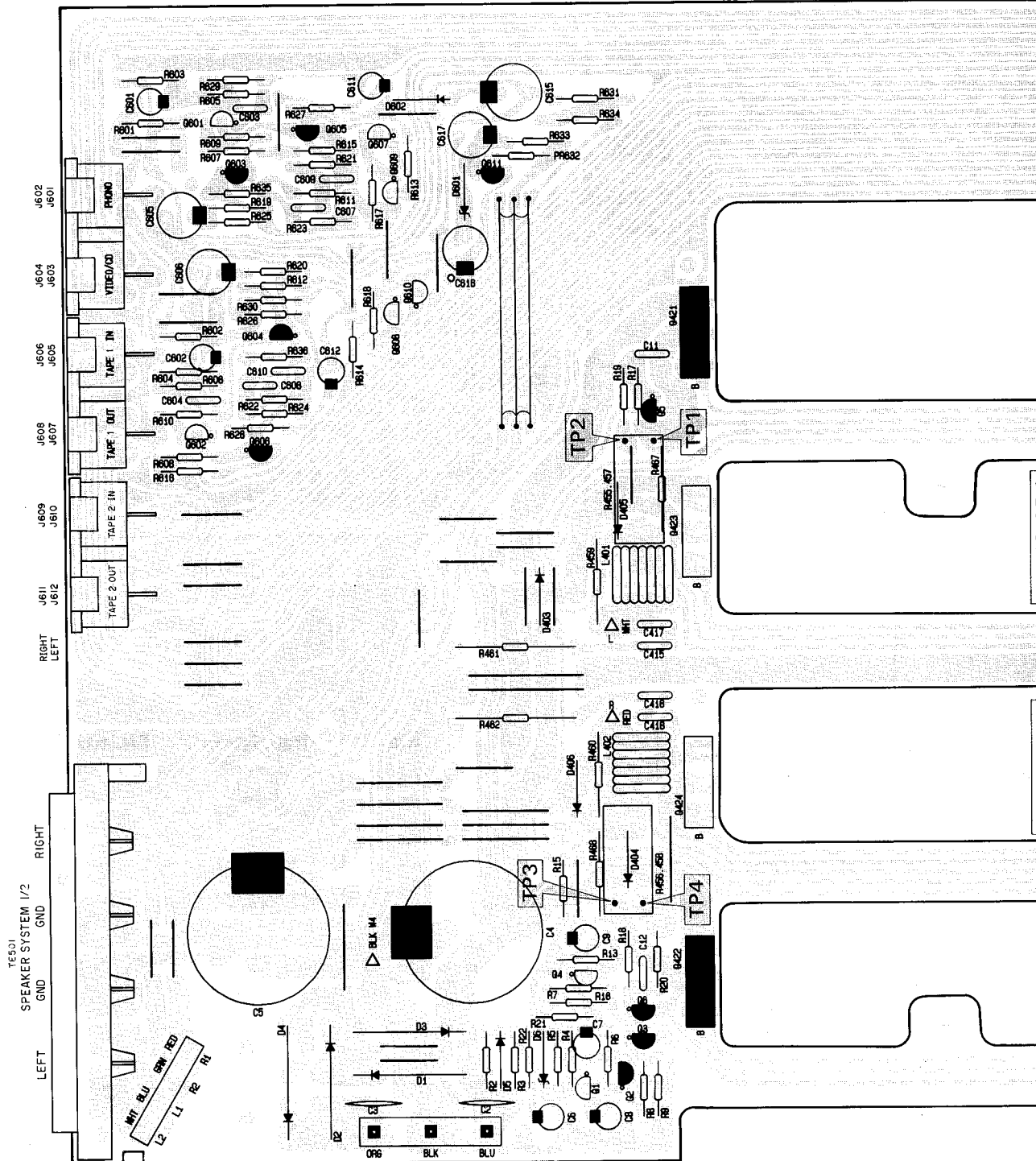

F

G

H

I

J

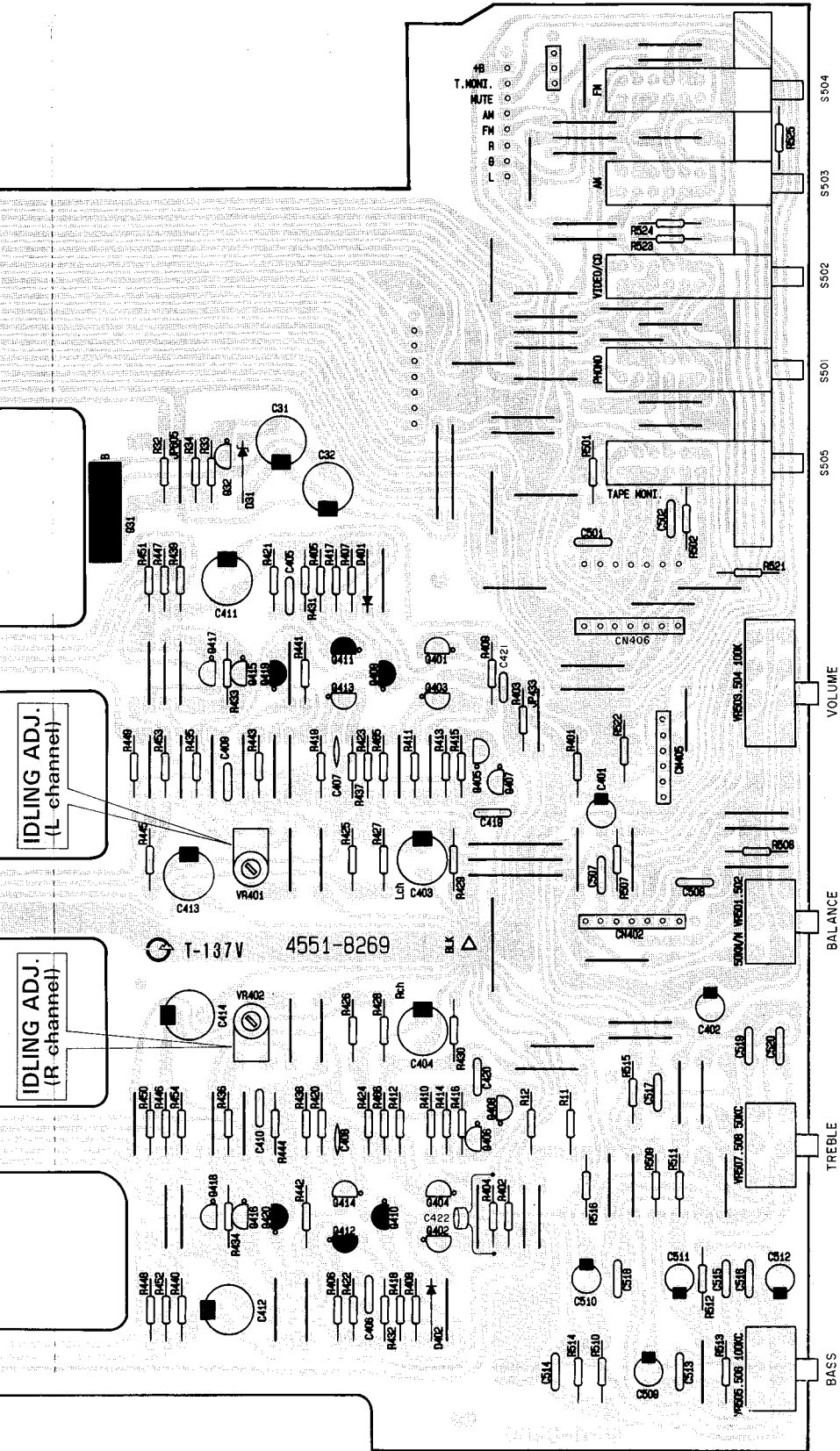

**PCB-7** Headphone Jack  
P. C. Board

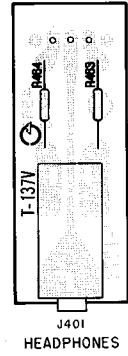

**PCB-8** Speaker Switches  
P. C. Board

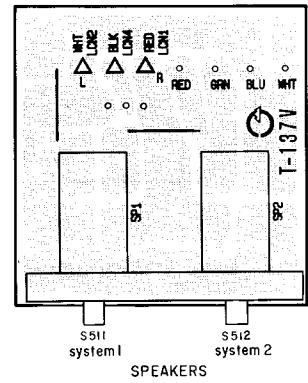

**PCB-10** Lamp P. C. Board

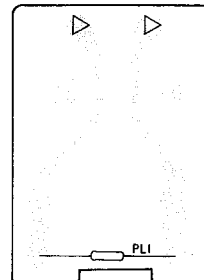

## ELECTRICAL PARTS LIST

Ref. No.	Part No.	Description	Ref. No.	Part No.	Description
<b>CHASSIS MISCELLANEOUS</b>					
△ P1	4161-71151	Power Cord	Q251	5613-RN1203	RN1203
△ T1	5584-701511	Power Transformer	Q252	5615-2SJ103(G)	F.E.T., 2SJ103(G)
△ SO1/	4474-157	AC Outlet, Unswitched	Q351	5613-2603(E)	2SC2603(E) or (F)
△ SO2		Switched	Q352	5611-1115(E)	2SA1115(E) or (F)
△ CO1	4443-712	Connector, Power Cord	Q353	5611-1115(E)	2SA1115(E) or (F)
△ F1	5732-252031	Fuse, 2.5A, 125V	Q354	5611-1115(E)	2SA1115(E) or (F)
△ R1	5135-335J50P	3.3MΩ, 1/2W, CAR	Q355	5613-2603(E)	2SC2603(E) or (F)
	5911-250	AM Loop Antenna	Q356	5613-2603(E)	2SC2603(E) or (F)
LUG1	4211-4	Lug Terminal	Q701	5616-2SK117(Y)	F.E.T., 2SK117(Y)
LUG2	4211-4	Lug Terminal	Q702	5613-2240(BL)	2SC2240(BL) or (GR)
LUG3	4211-4	Lug Terminal	Q703	5611-1115(E)	2SA1115(E) or (F)
	1397-6	Dipole Antenna	Q704	5613-RN1203	RN1203
			Q705	5613-RN1203	RN1203
			Q710	5613-2603(E)	2SC2603(E) or (F)
<b>PCB-1 TUNER P. C. BOARD</b>					
<b>RESISTORS</b>					
△ R211	5102-1014713	100Ω, 1/4W, FR	D121	5631-1S2473	1S2473
△ R373	5102-4R74713	4.7Ω, 1/4W, FR	D122	5631-1S2473	1S2473
△ R701	5102-4704713	47Ω, 1/4W, FR	D251	5633-1SV149	1SV149
△ R764	5102-2204713	22Ω, 1/4W, FR	D252	5633-1SV149	1SV149
<b>CONTROLS</b>					
VR201	5101-20371920	20kΩ	D351	5631-1S2473	1S2473
VR202	5101-10471920	100kΩ	D352	5631-1S2473	1S2473
VR301	5101-10471920	100kΩ	D353	5631-1S2473	1S2473
<b>CAPACITORS</b>					
C121	5345-105F041	1μF/50V, EC	D354	5631-1S2473	1S2473
C205	5345-106C041	10μF/16V, EC	D355	5631-1S2473	1S2473
C206	5359-1015851	100pF/100V, PC	D356	5631-1S2473	1S2473
C211	5345-107C041	100μF/16V, EC	D357	5631-1S2473	1S2473
C213	5345-225F041	2.2μF/50V, EC	D358	5631-1S2473	1S2473
C215	5345-107C041	100μF/16V, EC	D358	5631-1S2473	1S2473
C216	5345-106C041	10μF/16V, EC	D359	5631-1S2473	1S2473
C252	5359-4315851	430pF/100V, PC	D701	5635-HZ7B2L	ZD, HZ7B2L
C255	5345-106C041	10μF/16V, EC	D702	5631-1S2473	1S2473
C258	5345-475D041	4.7μF/25V, EC	D703	5631-1S2473	1S2473
C259	5345-335D041	3.3μF/25V, EC	D704	5635-HZ6B1L	ZD, HZ6B1L
C260	5345-106C041	10μF/16V, EC	D705	5631-1S2473	1S2473
C264	5345-226C0952	22μF/16V, EC	D706	5631-1S2473	1S2473
C301	5345-226C0952	22μF/16V, EC	D707	5631-1S2473	1S2473
C302	5345-107C041	100μF/16V, EC	D725	5635-HZ11A2L	ZD, HZ11A2L
C303	5359-1025851	1000pF/100V, PC	<b>COILS</b>		
C304	5345-474F0952	0.47μF/50V, EC	L106	5995-703027	
C305	5345-224F0952	0.22μF/50V, EC	L201	5995-2R2K082	
C306	5345-106C041	10μF/16V, EC	L202	5995-2R2K082	
C307	5359-4715851	470pF/100V, PC	L203	5995-2R2K082	
C308	5359-4715851	470pF/100V, PC	L251	5933-70428	
C311	5345-225F0952	2.2μF/50V, EC	L252	5922-00112	
C312	5345-225F0952	2.2μF/50V, EC	L701	5995-2R2269	
C313	5345-225F0952	2.2μF/50V, EC	<b>TRANSFORMERS</b>		
C314	5359-1015851	100pF/100V, PC	T201	5572-00113	
C351	5345-106C041	10μF/16V, EC	T251	5552-70114	
C352	5345-106C041	10μF/16V, EC	<b>MISCELLANEOUS</b>		
C353	5345-108C041	1000μF/16V, EC	6114-7133		FM Tuner Ass'y
C354	5345-106C041	10μF/16V, EC	CF201	5671-7120A	Ceramic Filter
C701	5345-228A041	2200μF/6.3V, EC	CF202	5671-7120A	Ceramic Filter
C702	5345-227B041	220μF/10V, EC	CF251	5671-7138F	Ceramic Filter
C703	5345-227B041	220μF/10V, EC	CF252	5671-7137C	Ceramic Filter
C707	5345-476C041	47μF/16V, EC	CF301	5693-CSB456F1	Ceramic Filter
C714	5345-334F0951	0.33μF/50V, EC	LPF301	5214-75	LC Composite
C715	5345-225F041	2.2μF/50V, EC	LPF302	5214-75	LC Composite
C716	5345-225F041	2.2μF/50V, EC	TE101	4214-164	Antenna Terminal
C723	5345-476C041	47μF/16V, EC	TE102	4214-166	Antenna Terminal, 75Ω
C724	5345-107C041	100μF/16V, EC	<b>UNBAL</b>		
TC251	5371-93	Trimmer Capacitor	X701	5691-00720022	Crystal Osc.
TC252	5371-93	Trimmer Capacitor	CN1	4443-050185	Connector, 5 Pos.
<b>INTEGRATED CIRCUITS</b>					
IC201	5653-LA1265	LA1265	CN2	4443-050185	Connector, 5 Pos.
IC301	5653-LA3410	LA3410	CN4	4443-100185	Connector, 10 Pos.
IC351	5652-BA6124	BA6124	CN5	4443-077114	Connector, 7 Pos.
IC701	5654-TD6104P	TD6104P	CN6	4443-030185	Connector, 3 Pos.
IC702	5654-TC9147BP	TC9147BP	CN401	4443-080185	Connector, 8 Pos.
<b>TRANSISTORS</b>					
Q121	5613-2603(E)	2SC2603(E) or (F)	<b>PCB-2 POWER AMP. P. C. BOARD</b>		
Q122	5611-1115(E)	2SA1115(E) or (F)	<b>RESISTORS</b>		
Q201	5613-380(R)	2SC380(R)	△ R32	5102-2R7579	2.7Ω, 1/4W, FR
			△ R34	5102-3314715	330Ω, 1/4W, FR
			△ R417	5102-3314715	330Ω, 1/4W, FR
			△ R418	5102-3314715	330Ω, 1/4W, FR
			△ R439	5102-2204715	22Ω, 1/4W, FR
			△ R440	5102-2204715	22Ω, 1/4W, FR
			△ R445	5102-2204715	22Ω, 1/4W, FR

Ref. No.	Part No.	Description	Ref. No.	Part No.	Description
△ R446	5102-2204715	22Ω, 1/4W, FR		<b>TRANSISTORS</b>	
△ R447	5102-1014715	100Ω, 1/4W, FR	Q1	5613-2603(F)	2SC2603(F) or (E)
△ R448	5102-1014715	100Ω, 1/4W, FR	Q2	5611-1115(F)	2SA1115(F) or (E)
△ R449	5102-1014715	100Ω, 1/4W, FR	Q3	5611-1115(F)	2SA1115(F) or (E)
△ R450	5102-1014715	100Ω, 1/4W, FR	Q4	5613-2603(F)	2SC2603(F) or (E)
△ R451	5102-1004715	10Ω, 1/4W, FR	Q5	5611-970(BL)	2SA970(BL)
△ R452	5102-1004715	10Ω, 1/4W, FR	Q6	5611-970(BL)	2SA970(BL)
△ R453	5102-1004715	10Ω, 1/4W, FR	Q31	5612-1015(O)	2SB1015(O)
△ R454	5102-1004715	10Ω, 1/4W, FR	Q32	5613-2603(F)	2SC2603(F) or (E)
R455	5273-R33672	0.33Ω, 3W, CR	Q401	5613-2240(BL)	2SC2240(BL)
R456	5273-R33672	0.33Ω, 3W, CR	Q402	5613-2240(BL)	2SC2240(BL)
R457	5273-R33672	0.33Ω, 3W, CR	Q403	5613-2240(BL)	2SC2240(BL)
R458	5273-R33672	0.33Ω, 3W, CR	Q404	5613-2240(BL)	2SC2240(BL)
R461	5173-100571	10Ω, 2W, MR	Q405	5613-2603(F)	2SC2603(F) or (E)
R462	5173-100571	10Ω, 2W, MR	Q406	5613-2603(F)	2SC2603(F) or (E)
R467	5171-1R5571	1.5Ω, 1W, MR	Q407	5613-2603(F)	2SC2603(F) or (E)
R468	5171-1R5571	1.5Ω, 1W, MR	Q408	5613-2603(F)	2SC2603(F) or (E)
R621	5174-Z412228	41.2kΩ, 1/4W, MR	Q409	5611-970(BL)	2SA970(BL)
R622	5174-Z412228	41.2kΩ, 1/4W, MR	Q410	5611-970(BL)	2SA970(BL)
△ R632	5102-2214715	220Ω, 1/4W, FR	Q411	5612-648(C)	2SB648(C)
	<b>CONTROLS</b>		Q412	5612-648(C)	2SB648(C)
VR401	5101-30171920	300Ω	Q413	5614-668A(C)	2SD668A(C)
VR402	5101-30171920	300Ω	Q414	5614-668A(C)	2SD668A(C)
VR501/	5113-50399122	50kΩMN, Balance	Q415	5613-945(K)	2SC945(K) or (P)
VR502			Q416	5613-945(K)	2SC945(K) or (P)
VR503/	5113-10498122	100kΩ, Volume	Q417	5614-667A(C)	2SD667A(C)
VR504			Q418	5614-667A(C)	2SD667A(C)
VR505/	5113-10441122	100kΩC, Bass	Q419	5612-647A(C)	2SB647A(C)
VR506			Q420	5612-647A(C)	2SB647A(C)
VR507/	5113-50342122	50kΩC, Treble	Q421	5611-1265(O)	2SA1265(O)
VR508			Q422	5611-1265(O)	2SA1265(O)
	<b>CAPACITORS</b>		Q423	5613-3182(O)	2SC3182(O)
C4	5341-808Y0959	8800μF/45V, EC	Q424	5613-3182(O)	2SC3182(O)
C5	5341-808Y0959	8800μF/45V, EC	Q601	5613-2320L(F)	2SC2320L(F)
C6	5345-106F041	10μF/50V, EC	Q602	5613-2320L(F)	2SC2320L(F)
C7	5345-106F041	10μF/50V, EC	Q603	5611-999L(F)	2SA999L(F)
C8	5345-107B041	100μF/10V, EC	Q604	5611-999L(F)	2SA999L(F)
C9	5345-105F041	1μF/50V, EC	Q605	5611-1115(F)	2SA1115(F) or (E)
C31	5345-107C041	100μF/16V, EC	Q606	5611-1115(F)	2SA1115(F) or (E)
C32	5345-107C041	100μF/16V, EC	Q607	5613-2603(F)	2SC2603(F) or (E)
C401	5345-476B0951	47μF/10V, EC	Q608	5613-2603(F)	2SC2603(F) or (E)
C402	5345-476B0951	47μF/10V, EC	Q609	5613-2603(F)	2SC2603(F) or (E)
C403	5345-227B041	220μF/10V, EC	Q610	5613-2603(F)	2SC2603(F) or (E)
C404	5345-227B041	220μF/10V, EC	Q611	5611-817(O)	2SA817(O)
C405	5359-2215851	220pF/100V, PC		<b>DIODES</b>	
C406	5359-2215851	220pF/100V, PC	△ D1	5632-ERC102FL	ERC102FL
C409	5359-1015851	100pF/100V, PC	△ D2	5632-ERC102FL	ERC102FL
C410	5359-1015851	100pF/100V, PC	△ D3	5632-ERC102FL	ERC102FL
C411	5345-476F041	47μF/50V, EC	△ D4	5632-ERC102FL	ERC102FL
C412	5345-476F041	47μF/50V, EC	D5	5636-1S2471	1S2471
C413	5345-476F041	47μF/50V, EC	D6	5635-HZ6A1L	ZD, HZ6A1L
C414	5345-476F041	47μF/50V, EC	D31	5635-HZ15-2L	ZD, HZ15-2L
C421	5353-100934	10pF/500V, MC	D401	5631-1S2473	1S2473
C422	5353-100934	10pF/500V, MC	D402	5631-1S2473	1S2473
C501	5359-1015851	100pF/100V, PC	D403	5632-S5566B	S5566B
C502	5359-1015851	100pF/100V, PC	D404	5632-S5566B	S5566B
C507	5359-1815851	180pF/100, PC	D405	5632-S5566B	S5566B
C508	5359-1815851	180pF/100, PC	D406	5632-S5566B	S5566B
C509	5345-225F0951	2.2μF/50V, EC	D601	5635-HZ20-1L	ZD, HZ20-1L
C510	5345-225F0951	2.2μF/50V, EC	D602	5632-S5566B	S5566B
C511	5345-106C0951	10μF/16V, EC		<b>COILS</b>	
C512	5345-106C0951	10μF/16V, EC	L401	5991-7165	
C601	5345-106C0951	10μF/16V, EC	L402	5991-7165	
C602	5345-106C0951	10μF/16V, EC		<b>MISCELLANEOUS</b>	
C603	5359-1215851	120pF/100V, PC	S501/	4431-05207158	Push Switch, Phono,
C604	5359-1215851	120pF/100V, PC	S502/		Video/CD,
C605	5345-107D041	100μF/25V, EC	S503/		AM,
C606	5345-107D041	100μF/25V, EC	S504/		FM,
C609	5359-2025851	2000pF/100V, PC	S505		Tape Monitor
C610	5359-2025851	2000pF/100V, PC	J601/	4486-15	6 Pin Jack, Phono,
C611	5345-475F0951	4.7μF/50V, EC	J602/		
C612	5345-475F0951	4.7μF/50V, EC	J603/		Video/CD,
C615	5345-337E041	330μF/35V, EC	J604/		
C616	5345-107D041	100μF/25V, EC	J605/		Tape 1 In
C617	5345-476D041	47μF/25V, EC	J606		
			J607/	4486-15	6 Pin Jack, Tape 1 Out,

Ref. No.	Part No.	Description
J608/ J609/ J610/ J611/ J612/ TE501	4214-165	Tape 2 In  Tape 2 Out  Terminal, Speaker System 1/2
CN402	4443-070185	Connector, 7 Pos.
CN405	4443-060185	Connector, 6 Pos.
CN406	4443-070185	Connector, 7 Pos.
PCB-3 FREQUENCY DISPLAY P. C. BOARD		
C721	<b>CAPACITORS</b> 5345-476C041	47 $\mu$ F/16V, EC
IC703	5654-TD6301AP	TD6301AP
Q706	<b>TRANSISTORS</b> 5613-2603(E)	2SC2603(E) or (F)
Q707	5613-RN1203	RN1203
Q708	5613-RN1203	RN1203
Q709	5611-1115(E)	2SA1115(E) or (F)
D709	<b>DIODES</b> 5635-HZ11A2L	ZD, HZ11A2L
	<b>MISCELLANEOUS</b> 5722-14	Frequency Display, FIP7F8S
RC701	5212-3	R Composite
RC702	5212-3	R Composite
RC703	5212-3	R Composite
LCN5	4163-077114	CLW, 7 Pos.
CN7	4443-040185	Connector, 4 Pos.
PCB-4 PUSH SWITCHES P. C. BOARD		
S506/ S507/ S508/ S509/ S510	4431-05127258	Push Switch, Tape, Loudness, Audio Mode, Subsonic Filter, FM Mute
CN401	4443-070185	Connector, 7 Pos.
CN403	4443-030185	Connector, 3 Pos.
CN407	4443-070185	Connector, 7 Pos.
PCB-5 TACT SWITCHES P. C. BOARD		
D711	<b>DIODES</b> 5637-GL5NG6	L.E.D., GL5NG6, Green, Memory
D712	5637-GL5NG6	L.E.D., GL5NG6, Green, Preset Memory 1
D713	5637-GL5NG6	L.E.D., GL5NG6, Green, Preset Memory 2
D714	5637-GL5NG6	L.E.D., GL5NG6, Green, Preset Memory 3
D715	5637-GL5NG6	L.E.D., GL5NG6, Green, Preset Memory 4
D716	5637-GL5NG6	L.E.D., GL5NG6, Green, Preset Memory 5
D717	5637-GL5NG6	L.E.D., GL5NG6, Green, Preset Memory 6
D718	5637-GL5NG6	L.E.D., GL5NG6, Green, Preset Memory 7
D719	5637-GL5NG6	L.E.D., GL5NG6, Green, Preset Memory 8
D721	5637-GL5NG6	L.E.D., GL5NG6, Green, Signal Strength
D722	5637-GL5NG6	L.E.D., GL5NG6, Green, Signal Strength
D723	5637-GL5NG6	L.E.D., GL5NG6, Green, Signal Strength
D724	5637-GL5NG6	L.E.D., GL5NG6, Green, Tuned
S701	<b>MISCELLANEOUS</b> 4431-A017169	Push Switch, Tuning Up
S702	4431-A017169	Push Switch, Tuning Down
S703	4431-A017169	Push Switch, Memory
S704	4431-A017169	Push Switch, Preset Memory 1

Ref. No.	Part No.	Description
S705	4431-A017169	Push Switch, Preset Memory 2
S706	4431-A017169	Push Switch, Preset Memory 3
S707	4431-A017169	Push Switch, Preset Memory 4
S708	4431-A017169	Push Switch, Preset Memory 5
S709	4431-A017169	Push Switch, Preset Memory 6
S710	4431-A017169	Push Switch, Preset Memory 7
S711	4431-A017169	Push Switch, Preset Memory 8
PCB-6 POWER SWITCH P. C. BOARD		
C1	<b>CAPACITORS</b> 5361-1030419	0.01 $\mu$ F/AC 125V, CC
C53	5345-105F041	1 $\mu$ F/50V, EC
Q51	<b>TRANSISTORS</b> 5613-2603(F)	2SC2603(F) or (E)
D51	<b>DIODES</b> 5631-1S2473	1S2473
D52	5631-1S2473	1S2473
S1	<b>MISCELLANEOUS</b> 4431-A01716 4472-0131	Push Switch, Power Holder, Fuse
PCB-7 HEADPHONE JACK P. C. BOARD		
R463	5171-471571	470 $\Omega$ , 1W, MR
R464	5171-471571	470 $\Omega$ , 1W, MR
J401	4451-00159	Jack, Headphones
PCB-8 SPEAKER SWITCHES P. C. BOARD		
S511/ S512	4431-02047366	Push Switch, Speakers System 1/2
PCB-9 LED P. C. BOARD		
D501	5637-GL5PR6	L.E.D., GL5PR6, Red, Tape Monitor
D502	5637-GL5PR6	L.E.D., GL5PR6, Red, Phono
D503	5637-GL5PR6	L.E.D., GL5PR6, Red, Video/CD
D504	5637-GL5PR6	L.E.D., GL5PR6, Red, AM
D505	5637-GL5PR6	L.E.D., GL5PR6, Red, FM
PCB-10 LAMP P. C. BOARD		
PL1	5731-0637263	Lamp

## KEY TO ABBREVIATIONS

FR	: Fuse Resistor
MR	: Metal Resistor
CR	: Cement Resistor
CAR	: Carbon Resistor
EC	: Electrolytic Capacitor
PC	: Polypropylene Capacitor
MC	: Mica Capacitor
CC	: Ceramic Capacitor
MPC	: Metalized Polyester Capacitor
SC	: Semiconductor Capacitor
ZD	: Zener Diode
CLW	: Connector with Lead Wire



SAFETY RELATED COMPONENT. USE ONLY  
EXACT REPLACEMENT PART AS SPECIFIED.